



2SA473

PNP EPITAXIAL SILICON TRANSISTOR

LOW FREQUENCY POWER AMPLIFIER

www.DataSheet4U.com Complement to 2SC1173

ABSOLUTE MAXIMUM RATINGS (T_A=25°C)

Characteristic	Symbol	Rating	Unit
Collector-Base Voltage	V _{CB0}	-30	V
Collector-Emitter Voltage	V _{CEO}	-30	V
Emitter-Base voltage	V _{EBO}	-5	V
Collector Current (DC)	I _C	-3	A
Collector Dissipation (T _c =25°C)	P _C	10	W
Junction Temperature	T _j	150	°C
Storage Temperature	T _{stg}	-50~150	°C

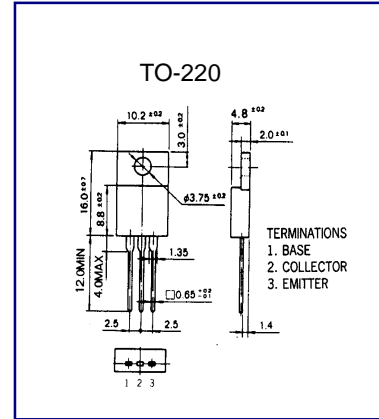

ELECTRICAL CHARACTERISTICS (T_A=25°C)

Characteristic	Symbol	Test Condition	Min	Typ	Max	Unit
Collector Cutoff Current	I _{CB0}	V _{CB} = -30V, I _E =0			-10	μA
Emitter Cutoff Current	I _{EBO}	V _{EB} = -5V, I _C =0			10	μA
DC Current Gain	h _{FE1}	V _{CE} = -1V, I _C =-0.1A	70		240	
Collector- Emitter Saturation Voltage	V _{CE(sat)}	I _C =-2A, I _B =-0.2A			-0.8	V
Current Gain Bandwidth Product	f _T	V _{CE} = -2V, I _C =-0.5A		100		MHZ