

## Features

- DSP Functions for CCD/CMOS Image Processing
- Baseline JPEG Compression/Decompression
- MPEG-1 Encode/Decode at 24 fps QVGA
- Compatible with Various Types of Display Devices
- Video Encoder Including Line Driver for NTSC/PAL TV Signal
- Integrated DACs for LCD Interface
- Direct Interface to Epson® and AU LCDs
- Digital Outputs Include: Composite, 16-bit YC, RGB 565
- SDRAM Interface – Supports from 16M Bits to 256M Bits
- Unified Memory Architecture (All Program and Data Stored in SDRAM)
- Support for Most Flash Card Interfaces (Atmel DataFlash®, MMC, SD, SSFDC, Memory Stick™)
- USB 1.1 Host/Slave Controller and USART Interfaces for PC Camera and Printing Applications
- Up to Nine External Interrupts and Wake-up Pin
- Serial Peripheral Interface for Loading Boot Code and Controlling Camera Components
- Two DACs for Camera Control Functions and Audio Output
- Four ADC Channels for Monitoring Camera Analog Inputs, Audio Input, Switch Input, Etc.
- Audio Data Interface for Connection to External Stereo ADC/DAC
- Three General-purpose Timers for Waveform Generation (PWM, Etc.) and Event Monitoring
- Up to 62 Pins for General-purpose I/O
- Up to 2M Bytes Program Space
- Support for RTOS
- All Low-level Software, Application Samples are Provided
- 208-ball BGA Package
- 1.8-Volt Core and 3.3V I/O Operation

Figure 1. Typical DSC Application Using AT76C113

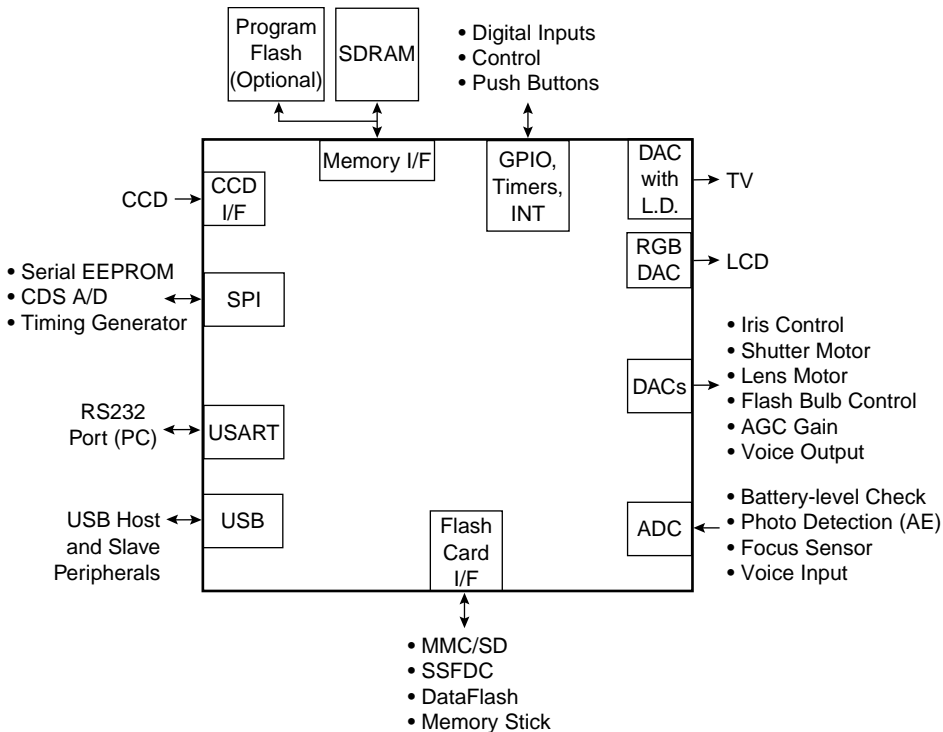

## High-Performance Digital Camera Processor

## AT76C113 Summary

Rev. 2391BS-IMAGE-05/03



Note: This is a summary datasheet. A complete document is available under NDA. For more information, please contact your local Atmel Sales Office.



## Description

The AT76C113 is a highly integrated solution for digital cameras. It combines a number of functions that are required in implementing digital cameras.

- Image data acquisition and capturing from either CCD or CMOS imagers
- Image display
- Image processing and image storing
- Overall camera management
- Control of general-purpose I/O functions
- Data communication
- Control of user functions
- On-screen Display

AT76C113 also provides a large number of interfaces that allow camera manufacturers to directly access a variety of devices that may be present in a digital camera.

- Communication with PCs
- Communication with Flash cards
- Serial communication ports for controlling other devices in the camera

The design is based on an ARM<sup>®</sup> microprocessor that controls the entire chip. A number of hardware resources, controlled by ARM, perform digital camera functions such as image DSP processing, JPEG coding/decoding, MPEG-1 coding/decoding, DMA access to SDRAM, and video encoding. All these computationally-intensive functions are implemented in hardware which can be programmed according to user specifications, thus allowing ARM to be free for other user-defined functions.

## Part Versions

The AT76C113 device comes in six versions, each with slightly different features. These are summarized in Table 1. In the rest of this document, the AT76C113-HU part is discussed.

**Table 1.** AT76C113 Part Versions

Part Number	Maximum Imager Resolution (Pixels)	Maximum SDRAM Size (Mbytes)	USB Functionality
AT76C113-S	≤ 2M	128	Slave Only
AT76C113-U	≤ 2M	128	Slave and Host
AT76C113-H	> 2M	512	Slave Only
AT76C113-HU	> 2M	512	Slave and Host
AT76C113-P	> 2M	512	Slave Only
AT76C113-PU	> 2M	512	Slave and Host

## Capabilities

- Supports up to 16-megapixel CCDs/CMOS (10 - 35 MHz CCDs)
- CCD colors are limited to the Bayer arrangements of the RGB primary colors
- Interfaces to 16 - 256-Mbit SDRAM, one or two pieces
- 30 frames/sec video display mode (NTSC)
- 30 frames/sec capture mode (VGA resolution)
- 24 frames/sec MPEG-1 encode/decode (QVGA resolution)
- Up to 1.5M bytes/sec read/write from/to Flash cards
- 2M bytes external Flash ROM for program space
- Full-speed USB 1.1 Host/Slave Controller (mass storage and image class for slave operation)
- Maximum 70 mA current in normal operation
- 1 - 5 mA in standby mode, < 100  $\mu$ A current in sleep mode



## Atmel Corporation

2325 Orchard Parkway  
San Jose, CA 95131  
Tel: 1(408) 441-0311  
Fax: 1(408) 487-2600

## Regional Headquarters

### Europe

Atmel Sarl  
Route des Arsenalux 41  
Case Postale 80  
CH-1705 Fribourg  
Switzerland  
Tel: (41) 26-426-5555  
Fax: (41) 26-426-5500

### Asia

Room 1219  
Chinachem Golden Plaza  
77 Mody Road Tsimshatsui  
East Kowloon  
Hong Kong  
Tel: (852) 2721-9778  
Fax: (852) 2722-1369

### Japan

9F, Tonetsu Shinkawa Bldg.  
1-24-8 Shinkawa  
Chuo-ku, Tokyo 104-0033  
Japan  
Tel: (81) 3-3523-3551  
Fax: (81) 3-3523-7581

## Atmel Operations

### Memory

2325 Orchard Parkway  
San Jose, CA 95131  
Tel: 1(408) 441-0311  
Fax: 1(408) 436-4314

### Microcontrollers

2325 Orchard Parkway  
San Jose, CA 95131  
Tel: 1(408) 441-0311  
Fax: 1(408) 436-4314

La Chantrerie  
BP 70602  
44306 Nantes Cedex 3, France  
Tel: (33) 2-40-18-18-18  
Fax: (33) 2-40-18-19-60

### ASIC/ASSP/Smart Cards

Zone Industrielle  
13106 Rousset Cedex, France  
Tel: (33) 4-42-53-60-00  
Fax: (33) 4-42-53-60-01

1150 East Cheyenne Mtn. Blvd.  
Colorado Springs, CO 80906  
Tel: 1(719) 576-3300  
Fax: 1(719) 540-1759

Scottish Enterprise Technology Park  
Maxwell Building  
East Kilbride G75 0QR, Scotland  
Tel: (44) 1355-803-000  
Fax: (44) 1355-242-743

### RF/Automotive

Theresienstrasse 2  
Postfach 3535  
74025 Heilbronn, Germany  
Tel: (49) 71-31-67-0  
Fax: (49) 71-31-67-2340

1150 East Cheyenne Mtn. Blvd.  
Colorado Springs, CO 80906  
Tel: 1(719) 576-3300  
Fax: 1(719) 540-1759

### Biometrics/Imaging/Hi-Rel MPU/ High Speed Converters/RF Datacom

Avenue de Rochepleine  
BP 123  
38521 Saint-Egreve Cedex, France  
Tel: (33) 4-76-58-30-00  
Fax: (33) 4-76-58-34-80

---

### e-mail

[literature@atmel.com](mailto:literature@atmel.com)

### Web Site

<http://www.atmel.com>

**Disclaimer:** Atmel Corporation makes no warranty for the use of its products, other than those expressly contained in the Company's standard warranty which is detailed in Atmel's Terms and Conditions located on the Company's web site. The Company assumes no responsibility for any errors which may appear in this document, reserves the right to change devices or specifications detailed herein at any time without notice, and does not make any commitment to update the information contained herein. No licenses to patents or other intellectual property of Atmel are granted by the Company in connection with the sale of Atmel products, expressly or by implication. Atmel's products are not authorized for use as critical components in life support devices or systems.

© Atmel Corporation 2003. All rights reserved. Atmel® and combinations thereof, DataFlash® are the registered trademarks of Atmel Corporation or its subsidiaries. Epson® is the registered trademark of Seiko Epson Corporation (SEC). ARM® is a registered trademark and ICEbreaker™ is a trademark of Advanced Risc Machines Ltd. Memory Stick™ is a trademark of Sony Electronics Inc.

Other terms and product names may be the trademarks of others.



Printed on recycled paper.