

NPN Silicon RF Transistor

- For modulators and amplifiers in TV and VCR tuners

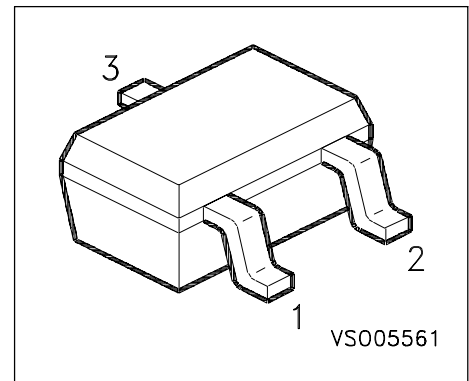

ESD: Electrostatic discharge sensitive device, observe handling precaution!

| Type | Marking | Ordering Code | Pin Configuration | | | Package |
|---------|---------|---------------|-------------------|-------|-------|---------|
| BF 771W | RBs | Q62702-F1519 | 1 = B | 2 = E | 3 = C | SOT-323 |

Maximum Ratings

| Parameter | Symbol | Values | Unit |
|---|-----------|----------------|------------------|
| Collector-emitter voltage | V_{CEO} | 12 | V |
| Collector-emitter voltage | V_{CES} | 20 | |
| Collector-base voltage | V_{CBO} | 20 | |
| Emitter-base voltage | V_{EBO} | 2 | |
| Collector current | I_C | 80 | mA |
| Base current | I_B | 10 | |
| Total power dissipation $T_S \leq 63 \text{ }^\circ\text{C}$ | P_{tot} | 580 | mW |
| Junction temperature | T_j | 150 | |
| Ambient temperature | T_A | - 65 ... + 150 | $^\circ\text{C}$ |
| Storage temperature | T_{stg} | - 65 ... + 150 | |

Thermal Resistance

| | | | |
|--|------------|------------|-----|
| Junction - soldering point ¹⁾ | R_{thJS} | ≤ 150 | K/W |
|--|------------|------------|-----|

1) T_S is measured on the collector lead at the soldering point to the pcb.

Electrical Characteristics at $T_A = 25^\circ\text{C}$, unless otherwise specified.

| Parameter | Symbol | Values | | | Unit |
|---|---------------|--------|------|------|---------------|
| | | min. | typ. | max. | |
| DC Characteristics | | | | | |
| Collector-emitter breakdown voltage $I_C = 1 \text{ mA}, I_B = 0$ | $V_{(BR)CEO}$ | 12 | - | - | V |
| Collector-emitter cutoff current $V_{CE} = 20 \text{ V}, V_{BE} = 0$ | I_{CES} | - | - | 100 | μA |
| Collector-base cutoff current $V_{CB} = 10 \text{ V}, I_E = 0$ | I_{CBO} | - | - | 100 | nA |
| Emitter-base cutoff current $V_{EB} = 1 \text{ V}, I_C = 0$ | I_{EBO} | - | - | 1 | μA |
| DC current gain $I_C = 30 \text{ mA}, V_{CE} = 8 \text{ V}$ | h_{FE} | 50 | 100 | 200 | - |

Electrical Characteristics at $T_A = 25^\circ\text{C}$, unless otherwise specified.

| Parameter | Symbol | Values | | | Unit |
|---|-----------------|--------|-------------|------|------|
| | | min. | typ. | max. | |
| AC Characteristics | | | | | |
| Transition frequency $I_C = 50 \text{ mA}$, $V_{CE} = 8 \text{ V}$, $f = 500 \text{ MHz}$ | f_T | 6 | 8 | - | GHz |
| Collector-base capacitance $V_{CB} = 10 \text{ V}$, $f = 1 \text{ MHz}$ | C_{cb} | - | 0.74 | 0.1 | pF |
| Collector-emitter capacitance $V_{CE} = 10 \text{ V}$, $f = 1 \text{ MHz}$ | C_{ce} | - | 0.28 | - | |
| Emitter-base capacitance $V_{EB} = 0.5 \text{ V}$, $f = 1 \text{ MHz}$ | C_{eb} | - | 1.8 | - | |
| Noise figure $I_C = 10 \text{ mA}$, $V_{CE} = 8 \text{ V}$, $Z_S = Z_{\text{Sopt}}$ $f = 900 \text{ MHz}$ $f = 1.8 \text{ GHz}$ | F | - | 1.3 2.1 | - | dB |
| Power gain ²⁾ $I_C = 30 \text{ mA}$, $V_{CE} = 8 \text{ V}$, $Z_S = Z_{\text{Sopt}}$ $Z_L = Z_{\text{Lopt}}$ $f = 900 \text{ MHz}$ $f = 1.8 \text{ GHz}$ | G_{ma} | - | 15.5 10 | - | |
| Transducer gain $I_C = 30 \text{ mA}$, $V_{CE} = 8 \text{ V}$, $Z_S = Z_L = 50 \Omega$ $f = 900 \text{ MHz}$ $f = 1.8 \text{ GHz}$ | $ S_{21e} ^2$ | - | 13.5 7.5 | - | |

2) $G_{\text{ma}} = |S_{21}/S_{12}| (k - (k^2 - 1)^{1/2})$