

### NPN Silicon RF Transistor

- For medium power amplifiers
- Compression point  $P_{-1dB} = +19$  dBm at 1.8 GHz  
maximum available gain  $G_{ma} = 14$  dB at 1.8 GHz  
Noise figure  $F = 1.25$  dB at 1.8 GHz
- Transition frequency  $f_T = 24$  GHz
- Gold metalization for high reliability
- **SIEGET® 25 - Line**  
**Siemens Grounded Emitter Transistor**  
**25 GHz  $f_T$  - Line**

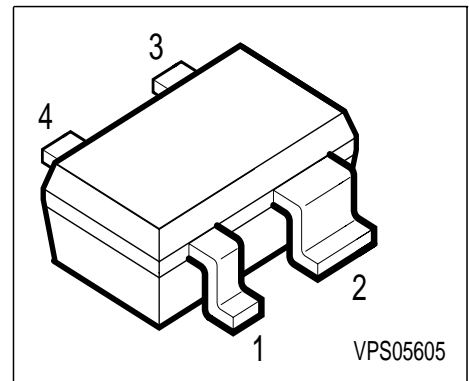

**ESD: Electrostatic discharge sensitive device, observe handling precaution!**

Type	Marking	Ordering Code	Pin Configuration				Package
BFP 450	ANs	Q62702-F1590	1 = B	2 = E	3 = C	4 = E	SOT-343

### Maximum Ratings

Parameter	Symbol	Value	Unit
Collector-emitter voltage	$V_{CEO}$	4.5	V
Collector-base voltage	$V_{CBO}$	15	
Emitter-base voltage	$V_{EBO}$	1.5	
Collector current	$I_C$	100	mA
Base current	$I_B$	10	
Total power dissipation, $T_S \leq 96$ °C	$P_{tot}$	450	mW
Junction temperature	$T_j$	150	°C
Ambient temperature	$T_A$	-65 ...+150	
Storage temperature	$T_{stg}$	-65 ...+150	

### Thermal Resistance

Junction - soldering point <sup>1)</sup>	$R_{thJS}$	$\leq 130$	K/W
--	------------	------------	-----

1) TS is measured on the collector lead at the soldering point to the pcb

**Electrical Characteristics** at  $T_A = 25^\circ\text{C}$ , unless otherwise specified.

Parameter	Symbol	Values			Unit
		min.	typ.	max.	
<b>DC characteristics</b>					
Collector-emitter breakdown voltage $I_C = 1 \text{ mA}, I_B = 0$	$V_{(BR)CEO}$	4.5	5	6.5	V
Collector-base cutoff current $V_{CB} = 5 \text{ V}, I_E = 0$	$I_{CBO}$	-	-	600	nA
Emitter-base cutoff current $V_{EB} = 1.5 \text{ V}, I_C = 0$	$I_{EBO}$	-	-	100	$\mu\text{A}$
DC current gain $I_C = 50 \text{ mA}, V_{CE} = 4 \text{ V}$	$h_{FE}$	50	80	150	-
<b>AC characteristics</b>					
Transition frequency $I_C = 90 \text{ mA}, V_{CE} = 3 \text{ V}, f = 1 \text{ GHz}$ $I_C = 90 \text{ mA}, V_{CE} = 3 \text{ V}, f = 2 \text{ GHz}$	$f_T$	- 15	24 17	- -	GHz
Collector-base capacitance $V_{CB} = 2 \text{ V}, f = 1 \text{ MHz}$	$C_{cb}$	-	0.48	0.75	pF
Collector-emitter capacitance $V_{CE} = 2 \text{ V}, f = 1 \text{ MHz}$	$C_{ce}$	-	1.33	-	
Emitter-base capacitance $V_{EB} = 0.5 \text{ V}, f = 1 \text{ MHz}$	$C_{eb}$	-	1.75	-	
Noise figure $I_C = 10 \text{ mA}, V_{CE} = 2 \text{ V}, Z_S = Z_{Sopt},$ $f = 1.8 \text{ GHz}$	$F$	-	1.25	1.6	dB
Power gain <sup>2)</sup> $I_C = 50 \text{ mA}, V_{CE} = 2 \text{ V}, Z_S = Z_{Sopt}, Z_L = Z_{Lopt},$ $f = 1.8 \text{ GHz}$	$G_{ma}$	-	14	-	dB
Insertion power gain $I_C = 50 \text{ mA}, V_{CE} = 2 \text{ V}, f = 1.8 \text{ GHz},$ $Z_S = Z_L = 50\Omega$	$ S_{21} ^2$	8	11	-	
Third order intercept point $I_C = 50 \text{ mA}, V_{CE} = 3 \text{ V}, Z_S = Z_{Sopt}, Z_L = Z_{Lopt},$ $f = 1.8 \text{ GHz}$	$IP_3$	-	29	-	dBm
1dB Compression point $I_C = 50 \text{ mA}, V_{CE} = 3 \text{ V}, f = 1.8 \text{ GHz},$ $Z_S = Z_{Sopt}, Z_L = Z_{Lopt}$	$P_{-1dB}$	-	19	-	

$$2) G_{ma} = |S_{21} / S_{12}| (k - (k^2 - 1)^{1/2})$$

### Common Emitter S-Parameters

<i>f</i>	<i>S</i> <sub>11</sub>		<i>S</i> <sub>21</sub>		<i>S</i> <sub>12</sub>		<i>S</i> <sub>22</sub>	
	MAG	ANG	MAG	ANG	MAG	ANG	MAG	ANG
<i>V</i> <sub>CE</sub> = 2V, <i>I</i> <sub>C</sub> = 50mA								
0.01	0.143	-30.7	69.9	174.8	0.0018	85.2	0.904	-6.6
0.1	0.469	-121.7	51.98	125.6	0.0139	59.6	0.744	-64.2
0.5	0.681	-172.4	14.86	90.7	0.0289	51.4	0.466	-146.1
1	0.705	173.1	7.26	74.6	0.047	55.7	0.464	-172.2
2	0.73	154.7	3.42	55	0.08	51.2	0.491	163.6
3	0.752	139.5	2.22	38.4	0.1183	42	0.529	145.5
4	0.783	124.1	1.62	22.4	0.1461	30.3	0.587	131.9
5	0.797	112.5	1.23	8.8	0.1633	20.7	0.606	119.5
6	0.813	103.7	1.01	-2.9	0.1864	12.6	0.625	108.9

### Common Emitter Noise Parameters

<i>f</i>	<i>F</i> <sub>min</sub> <sup>1)</sup>	<i>G</i> <sub>a</sub> <sup>1)</sup>	<i>Γ</i> <sub>opt</sub>		<i>R</i> <sub>N</sub>	<i>r</i> <sub>n</sub>	<i>F</i> <sub>50Ω</sub> <sup>2)</sup>	<i> S</i> <sub>21</sub> <i> </i> <sup>2 2)</sup>
	dB	dB	MAG	ANG	Ω	-	dB	dB
<i>V</i> <sub>CE</sub> = 2V, <i>I</i> <sub>C</sub> = 10mA								
0.9	0.9	15.5	0.29	175	2.7	0.054	0.98	16
1.8	1.25	11.8	0.47	-171	3	0.06	1.74	9.5
2.4	1.45	10.9	0.56	-159	3.5	0.07	2.23	6.8
3	1.7	8.5	0.62	-147	5.5	0.11	3.05	4.7
4	2.1	6.6	0.66	-127	15.5	0.31	4.49	1.9

1) Input matched for minimum noise figure, output for maximum gain

2) *Z*<sub>S</sub> = *Z*<sub>L</sub> = 50Ω

For more and detailed S- and Noise-parameters please contact your local Siemens distributor or sales office to obtain a Siemens Application Notes CD-ROM or see Internet: <http://www.siemens.de/Semiconductor/products/35/35.htm>

## SPICE Parameters (Gummel-Poon Model, Berkley-SPICE 2G.6 Syntax) :

### Transistor Chip Data

IS =	0.13125	fA	BF =	76.123	-	NF =	0.79652	-
VAF =	24.165	V	IKF =	0.58905	A	ISE =	28.341	pA
NE =	1.5563	-	BR =	21.254	-	NR =	1.2966	-
VAR =	13.461	V	IKR =	0.25878	A	ISC =	0.012292	A
NC =	0.70543	-	RB =	2.1659	$\Omega$	IRB =	0.013181	mA
RBM =	5.403	$\Omega$	RE =	0.45346		RC =	0.50084	$\Omega$
CJE =	3.2276	fF	VJE =	0.95292	V	MJE =	0.48672	-
TF =	7.5068	ps	XTF =	0.69972	-	VTF =	0.66148	V
ITF =	0.017655	mA	PTF =	0	deg	CJC =	1049.5	fF
VJC =	1.1487	V	MJC =	0.50644	-	XCJC =	0.28285	-
TR =	2.6912	ns	CJS =	0	F	VJS =	0.75	V
MJS =	0	-	XTB =	0	-	EG =	1.11	eV
XTI =	3	-	FC =	0.91274	-	TNOM	300	K

### C'-E'-Diode Data (Berkley-SPICE 2G.6 Syntax) :

IS =	25	fA	N =	1.05	-	RS =	5	$\Omega$
------	----	----	-----	------	---	------	---	----------

All parameters are ready to use, no scaling is necessary

### Package Equivalent Circuit:

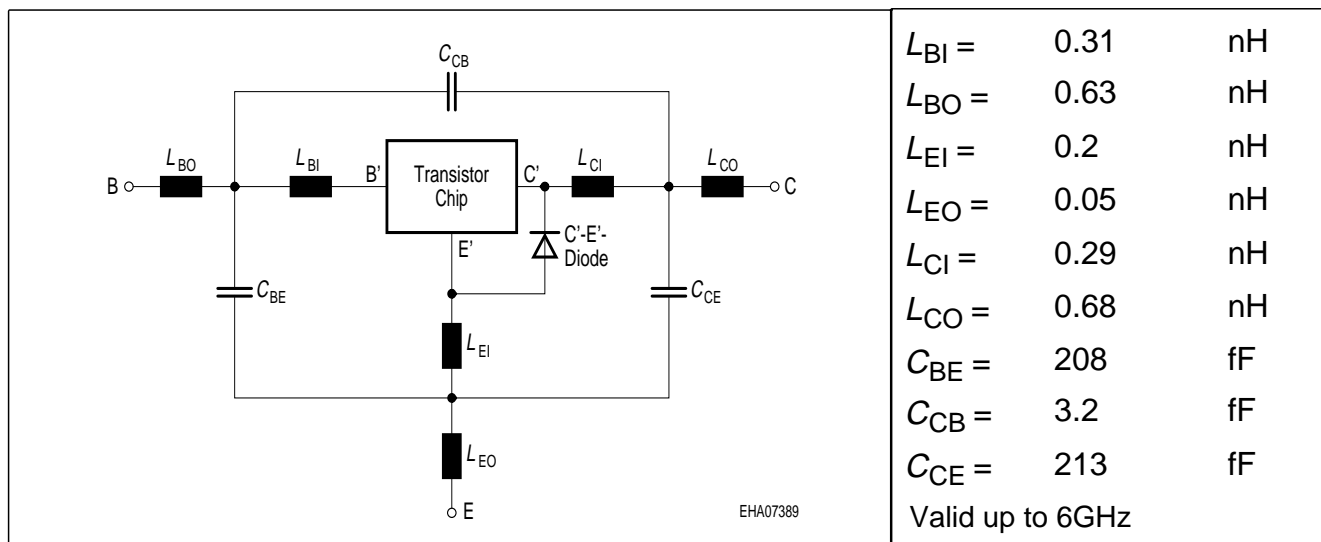

The SOT-343 package has two emitter leads. To avoid high complexity of the package equivalent circuit, both leads are combined in one electrical connection.

Extracted on behalf of SIEMENS Small Signal Semiconductors by:  
 Institut für Mobil-und Satellitentechnik (IMST)  
 © 1996 SIEMENS AG

For examples and ready to use parameters please contact your local Siemens distributor or sales office to obtain a Siemens CD-ROM or see Internet: <http://www.siemens.de/Semiconductor/products/35/35.htm>

**For non-linear simulation:**

- Use transistor chip parameters in Berkeley SPICE 2G.6 syntax for all simulators.
- If you need simulation of the reverse characteristics, add the diode with the C'-E'- diode data between collector and emitter.
- Simulation of package is not necessary for frequencies < 100MHz.  
For higher frequencies add the wiring of package equivalent circuit around the non-linear transistor and diode model.

**Note:**

- This transistor is constructed in a common emitter configuration. This feature causes an additional reverse biased diode between emitter and collector, which does not effect normal operation.

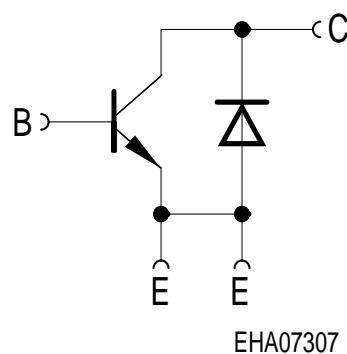

**Transistor Schematic Diagram**

The common emitter configuration shows the following advantages:

- Higher gain because of lower emitter inductance.
- Power is dissipated via the grounded emitter leads, because the chip is mounted on copper emitter leadframe.

Please note, that the broadest lead is the emitter lead.

The AC characteristics are verified by random sampling.

### Total power dissipation $P_{tot} = f(T_A^*, T_S)$

\* Package mounted on epoxy

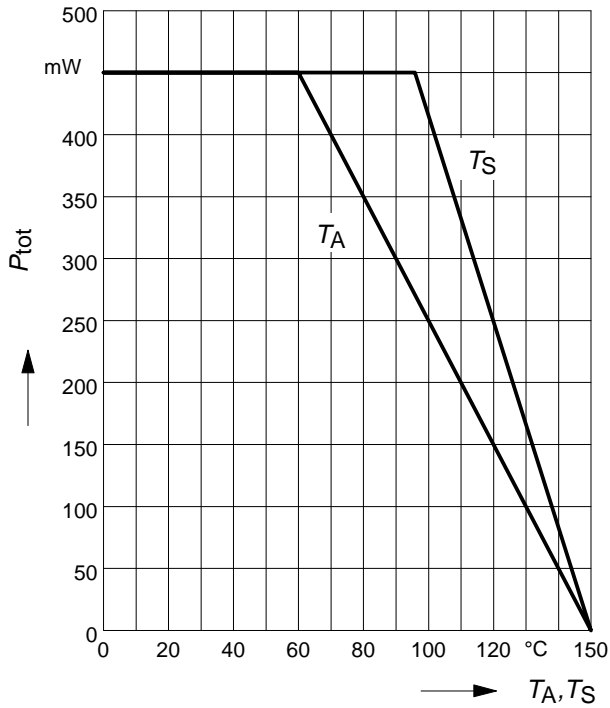

### Transition frequency $f_T = f(I_C)$

$f = 1$  GHz

$V_{CE} = \text{parameter in V}$

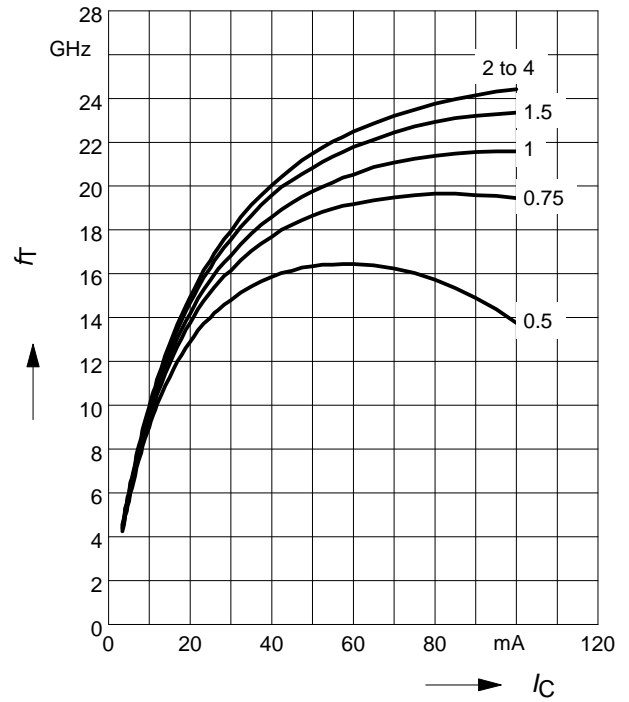

### Permissible Pulse Load $R_{thJS} = f(t_p)$

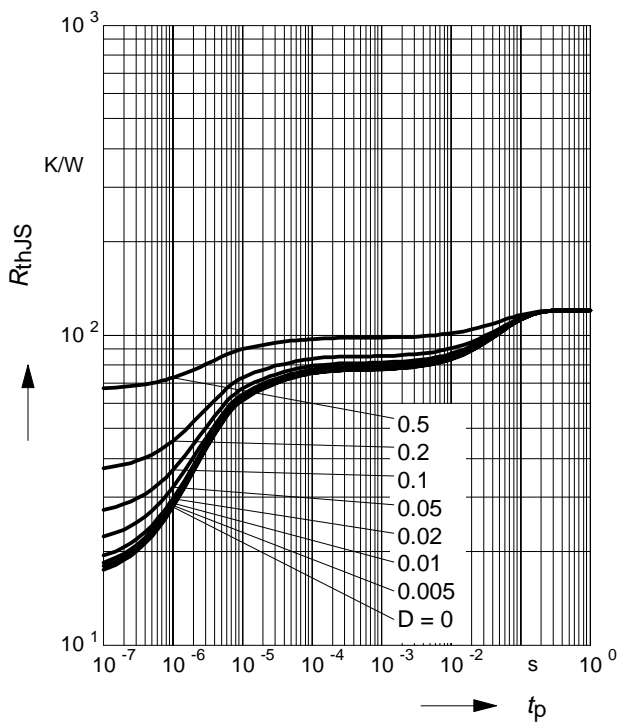

### Permissible Pulse Load

$$P_{totmax}/P_{totDC} = f(t_p)$$

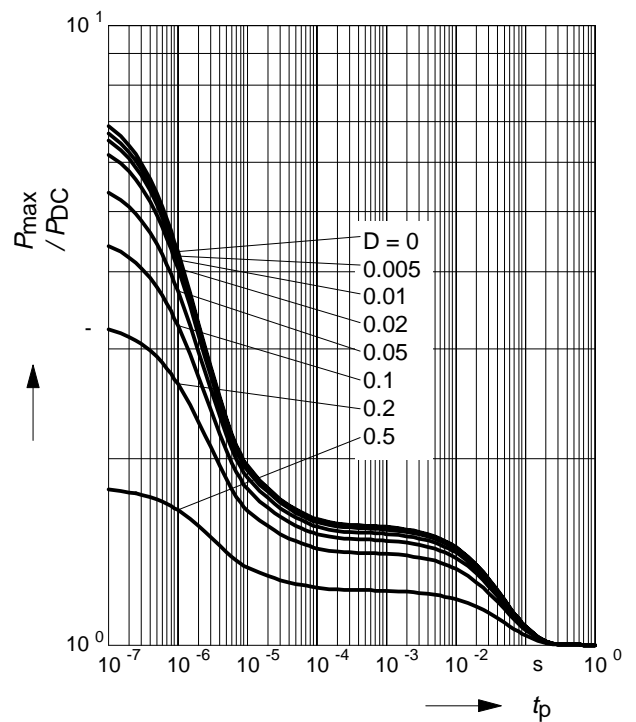

**Power gain  $G_{ma}$ ,  $G_{ms}$ ,  $|S_{21}|^2 = f(f)$**

$V_{CE} = 2V$ ,  $I_C = 50\text{ mA}$

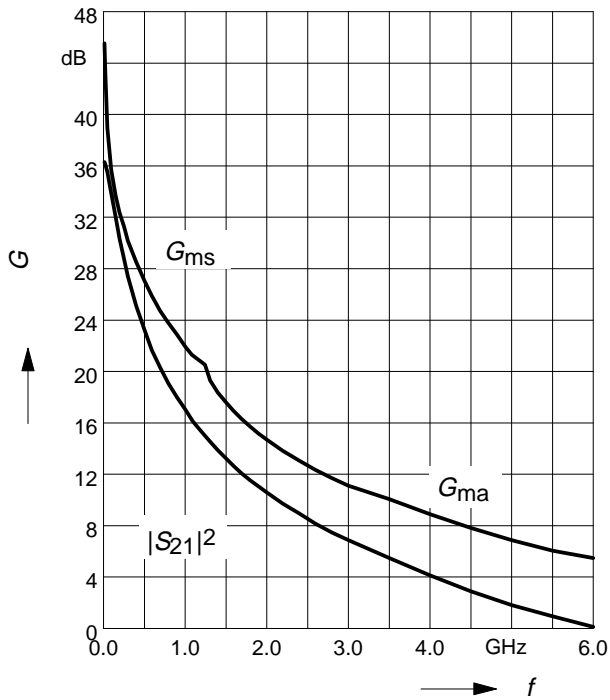

**Power gain  $G_{ma}$ ,  $G_{ms} = f(I_C)$**

$V_{CE} = 2V$

$f = \text{parameter in GHz}$

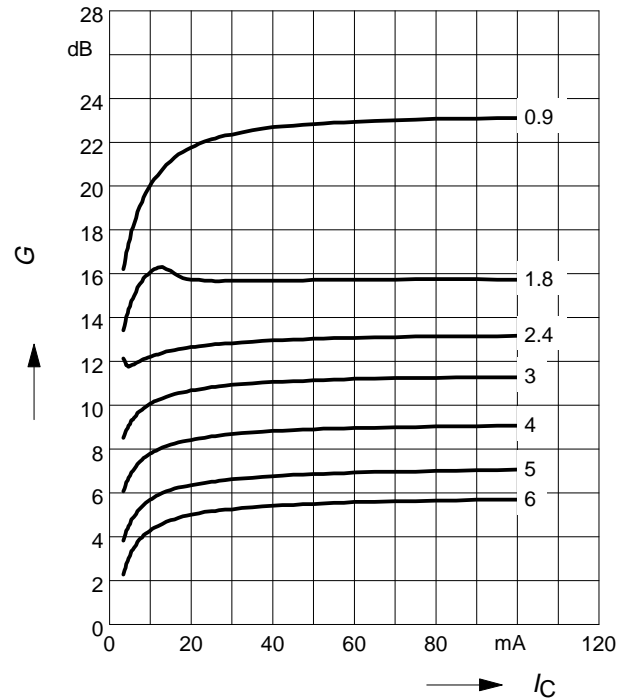

**Power gain  $G_{ma}$ ,  $G_{ms} = f(V_{CE})$**

$I_C = 50\text{ mA}$

$f = \text{Parameter in GHz}$

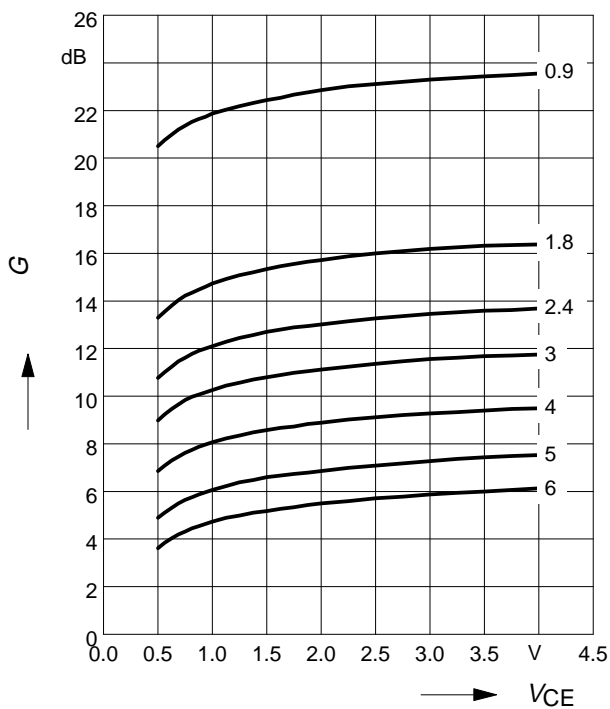

**Collector-base capacitance  $C_{cb} = f(V_{CB})$**

$V_{BE} = 0$ ,  $f = 1\text{ MHz}$

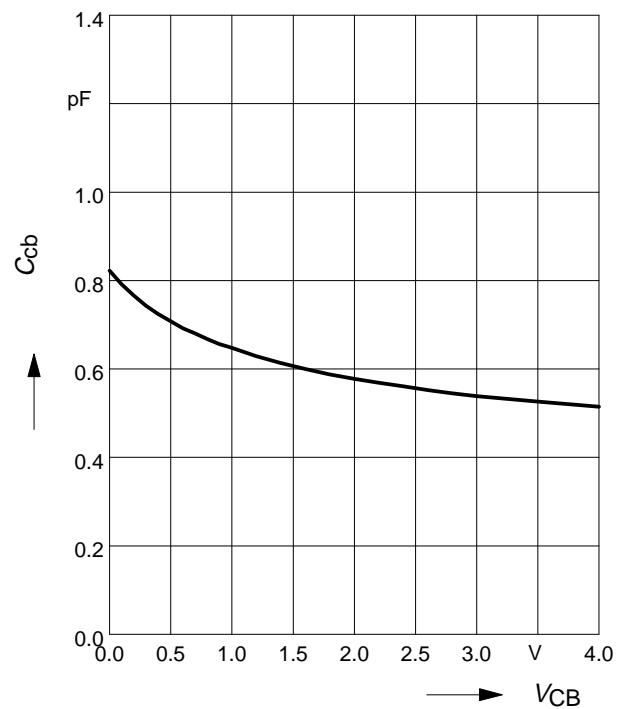

### Noise figure $F = f(I_C)$

$V_{CE} = 2\text{ V}$ ,  $Z_S = Z_{Sopt}$

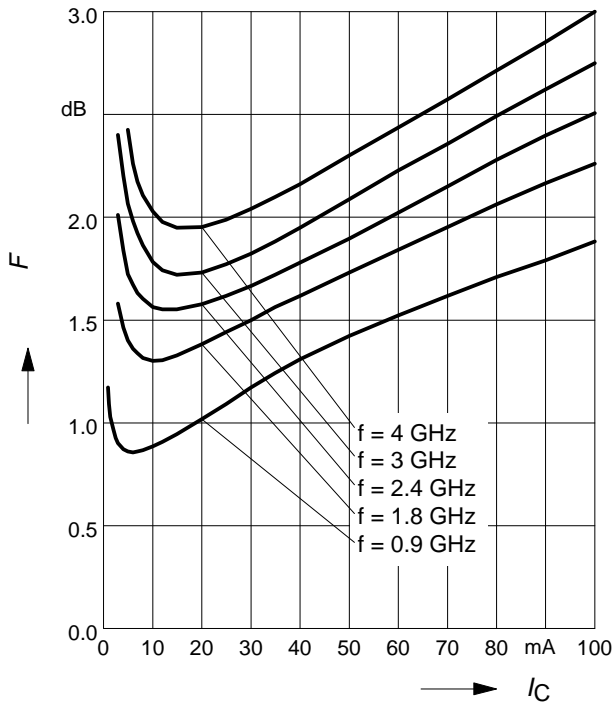

### Noise figure $F = f(I_C)$

$V_{CE} = 2\text{ V}$ ,  $f = 1.8\text{ GHz}$

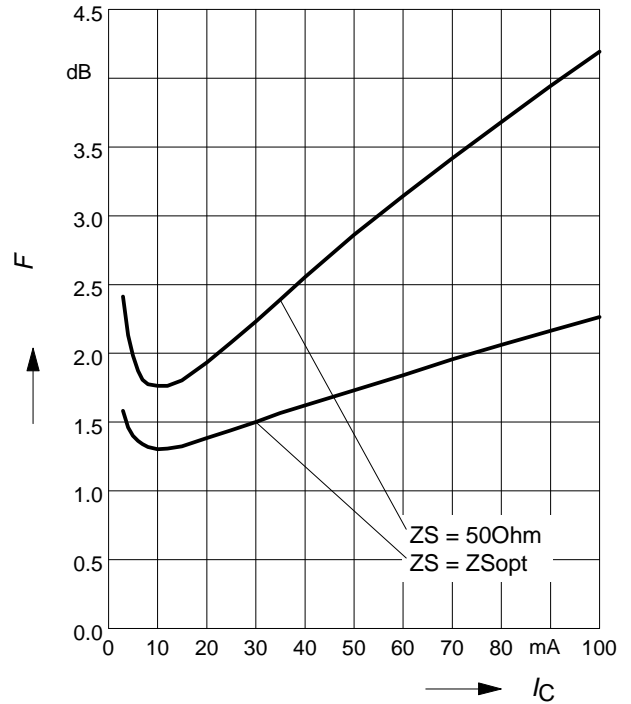

### Noise figure $F = f(f)$

$V_{CE} = 2\text{ V}$ ,  $Z_S = Z_{Sopt}$

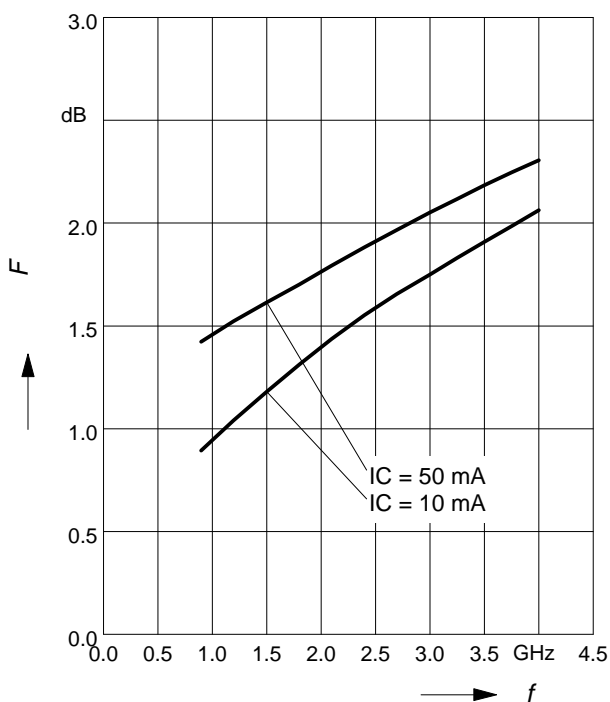

### Source impedance for min.

Noise Figure versus Frequency

$V_{CE} = 2\text{ V}$ ,  $I_C = 10\text{ mA} / 50\text{ mA}$

