

### Silicon Bipolar MMIC-Amplifier

#### Preliminary data

- Cascadable 50  $\Omega$ -gain block
- 16 dB typical gain at 1.0 GHz
- 12 dBm typical  $P_{-1dB}$  at 1.0 GHz
- 3 dB-bandwidth: DC to 1.2 GHz

#### Circuit Diagram

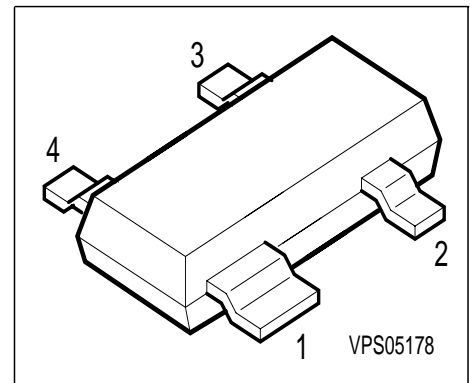
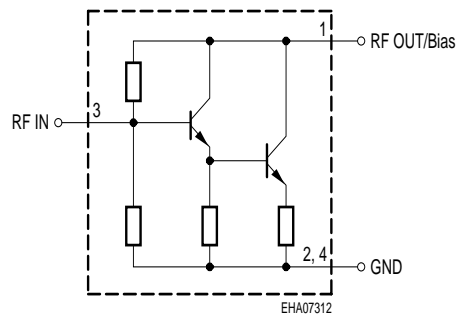

Type	Marking	Ordering Code	Pin Configuration				Package
BGA 318	BNs	Q62702-G0043	1 RFout/bias	2 GND	3 RFinput	4 GND	SOT-143

#### Maximum Ratings

Parameter	Symbol	Value	Unit
Device current	$I_D$	60	mA
Total power dissipation, $T_S \leq 99^\circ\text{C}$	$P_{tot}$	250	mW
$R_F$ input power	$P_{RFin}$	5	dBm
Junction temperature	$T_j$	150	°C
Ambient temperature	$T_A$	-65 ...+150	
Storage temperature	$T_{stg}$	-65 ...+150	

#### Thermal Resistance

Junction - soldering point <sup>1)</sup>	$R_{thJS}$	$\leq 205$	K/W
--	------------	------------	-----

1)  $T_S$  is measured on the collector lead at the soldering point to the pcb

**Electrical Characteristics** at  $T_A = 25\text{ }^\circ\text{C}$ , unless otherwise specified.

Parameter	Symbol	Values			Unit
		min.	typ.	max.	
<b>AC characteristics</b> ( $V_D = 4.7\text{ V}$ , $Z_0 = 50\text{ }\Omega$ )					
Insertion power gain $f = 0.1\text{ GHz}$ $f = 1\text{ GHz}$ $f = 1.8\text{ GHz}$	$ S_{21} ^2$	-	18 16 12	-	dB
Insertion point gain flatness $f = 0.1\text{ GHz to }0.6\text{ GHz}$	$\Delta  S_{21} ^2$	-	+0.7	-	
Noise figure $f = 0.1\text{ GHz}$ $f = 1\text{ GHz}$ $f = 2\text{ GHz}$	$NF$	-	3.5 4 5	-	
1dB compression point $f = 1\text{ GHz}$	$P_{-1\text{dB}}$	-	12	-	dBm
Return loss input $f = 0.1\text{ GHz to }2\text{ GHz}$	$RL_{\text{in}}$	-	14	-	dB
Return loss output $f = 0.1\text{ GHz to }3\text{ GHz}$	$RL_{\text{out}}$	-	10	-	

### Typical biasing configuration

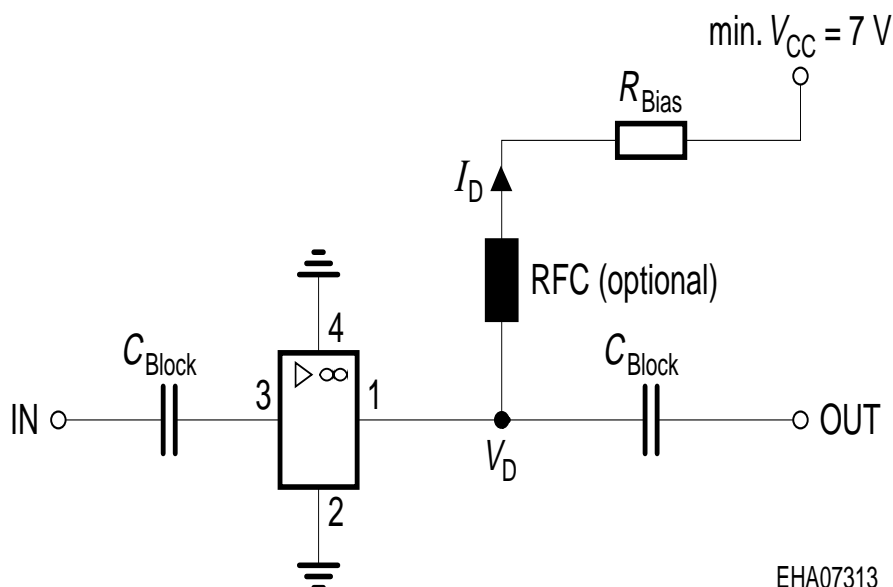

### S-Parameters at $T_A = 25\text{ °C}$

$f$	$S_{11}$		$S_{21}$		$S_{12}$		$S_{22}$	
	MAG	ANG	MAG	ANG	MAG	ANG	MAG	ANG
$V_D = 4.7\text{ V}, Z_0 = 50\text{ }\Omega$								
0.01	0.196	0.2	8.01	178.9	0.077	0.6	0.327	-0.5
0.1	0.193	-4.8	8	171.6	0.078	4.9	0.324	-8.6
0.3	0.194	-14.4	7.75	155.4	0.082	13.8	0.312	-25
0.5	0.191	-25.9	7.28	139.9	0.089	21.1	0.294	-41.2
0.8	0.184	-45	6.43	119.1	0.105	27.9	0.26	-62.9
1	0.175	-60.3	5.83	106.8	0.117	30.2	0.238	-76.2
1.9	0.185	-130.6	3.91	67.6	0.164	30.2	0.184	-113
2.4	0.241	-170.6	2.99	45.5	0.193	26.8	0.173	-124.4
3	0.298	159.6	2.38	27.6	0.218	22.8	0.178	-131.2

### Insertion power gain $|S_{21}|^2 = f(f)$

$V_D = 4.7\text{V}, I_D = 35\text{ mA}$

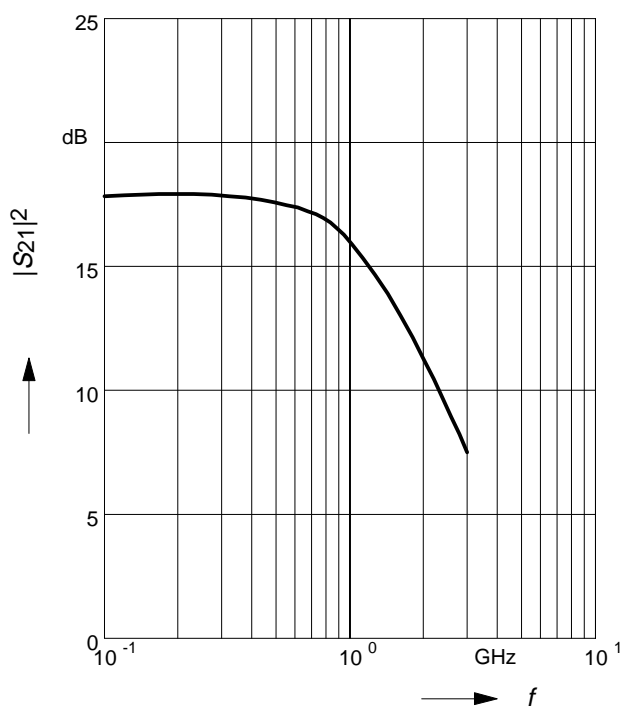

### Noise figure $NF = f(f)$

$V_D = 4.7\text{V}, I_D = 35\text{ mA}$

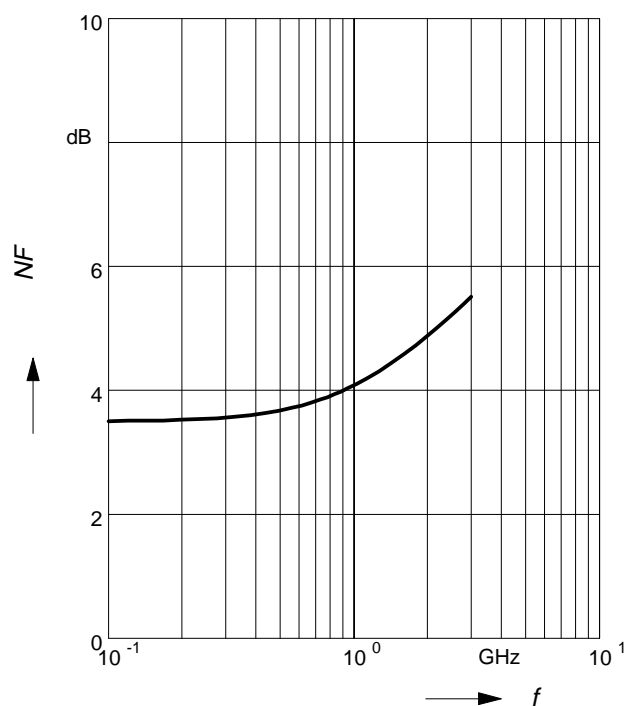

## Output power 1-dB-gain compression

$$P_{-1\text{dB}} = f(f)$$

$$V_D = 4.7\text{V}, I_D = 35\text{ mA}$$

