

The BGA619 Silicon-Germanium High IP3 Low Noise Amplifier in PCS Receiver Applications

Features

- Easy-to-use LNA MMIC in 70 GHz f_t SiGe technology
- Tiny „Green“ P-TSLP-7-1 package (no Lead or Halogen compounds)
- Low external component count
- Integrated output DC blocking capacitor, integrated RF choke on internal bias network
- Three gain steps
- Power off function
- High IP3 in all modes

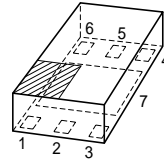

P-TSLP-7-1

Applications

- Low Noise Amplifier for 1900 MHz PCS wireless frontends (CDMA 2000).

Introduction

The BGA619 is an easy-to-use, low-cost **Low Noise Amplifier (LNA) MMIC** designed for use in today's PCS systems which require excellent linearity in each of several gain step modes. Based on Infineon's cost-effective 70 GHz f_T Silicon-Germanium (SiGe) B7HF bipolar process technology, the BGA619 offers a 1.5 dB noise figure and 14.9 dB of gain at 1.96 GHz with a current consumption of 6.5 mA in high gain mode. BGA619 offers impressive IIP3 performance of 7 dBm in High Gain mode, particularly for a three-gain step, low-cost, integrated MMIC.

The new LNA incorporates a 50 Ω pre-matched output with an integrated output DC blocking capacitor. The input is pre-matched, requiring an external DC blocking capacitor. An integrated, on-chip inductor eliminates the need for an external RF choke on the voltage supply pin. The operating mode of the device is determined by the voltage at the GS-pin. An integrated on/off feature provides for low power consumption and increased stand by time for PCS cellular handsets.

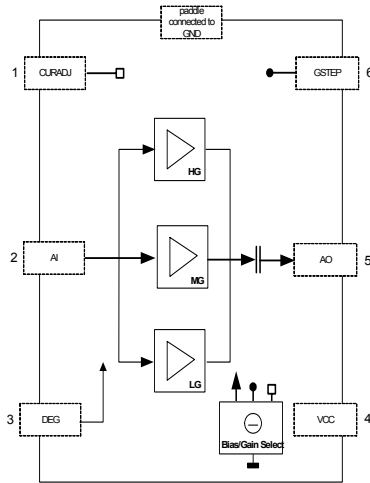

Figure 1 BGA619's Equivalent Circuit.

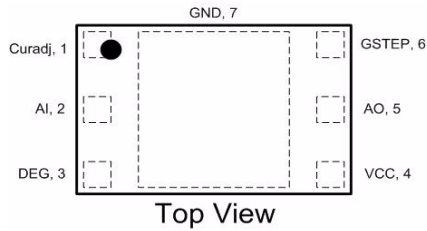

Figure 2 Pin Connections

Overview

The BGA619 has three gain steps and one off-mode which are used in PCS-band applications:

- High Gain Mode
- Mid Gain Mode
- Low Gain Mode
- OFF Mode

Mode selection is performed by applying a voltage to pin 6 (GSTEP) as described in [Table 1](#). The source that generates these mode-select voltages should be able to source or sink current. Please refer to the BGA619 datasheet for the maximum values of mode control current.

Table 1 Switching Modes for Gain Steps

Gain Mode	Gain Step Input Voltage [V]		Current into GS-pin [µA]
	Min	Max	typ
High Gain	2.2	2.4	65
Mid Gain	1.6	1.8	40
Low Gain	0.9	1.1	8
OFF	0.0	0.3	-35

The next table shows the measured performance of each of these gain modes. All measurement values presented in this application note include losses of both PCB and connectors - in other words, the reference planes used for measurements are the PCB's RF SMA connectors. Noise figure and gain results shown here would improve by 0.2 - 0.3 dB compared to the values shown if PCB losses were extracted.

All measurements are performed at 1960 MHz and at a typical supply voltage of 2.78 V.

Table 2 Performance Overview

Parameter	High Gain Mode	Mid Gain Mode	Low Gain Mode
Supply voltage	2.78 V	2.78 V	2.78 V
Supply current	6.5 mA	4.5 mA	2.9 mA
Gain	14.9 dB	2.2 dB	-9.5 dB
Noise Figure	1.5 dB	8 dB	16 dB
Input return loss	10.5 dB	8.5 dB	12.5 dB
Output return loss	11.5 dB	13 dB	13 dB
Reverse Isolation	25 dB	21 dB	23 dB
Input 3 rd order intercept point	7 dBm ¹⁾	6.5 dBm ²⁾	15 dBm ³⁾

¹⁾ -30 dBm per tone, f1=1950 MHz, Δf = 1 MHz

²⁾ -27 dBm per tone, f1=1950 MHz, Δf = 1 MHz

³⁾ -15 dBm per tone, f1=1950 MHz, Δf = 1 MHz

Board Configuration

The circuit in [Figure 3](#) shows the board configuration for BGA619 LNA. The Bill of materials for the application board can be found in [Table 3](#).

Figure 3 PCB board configuration

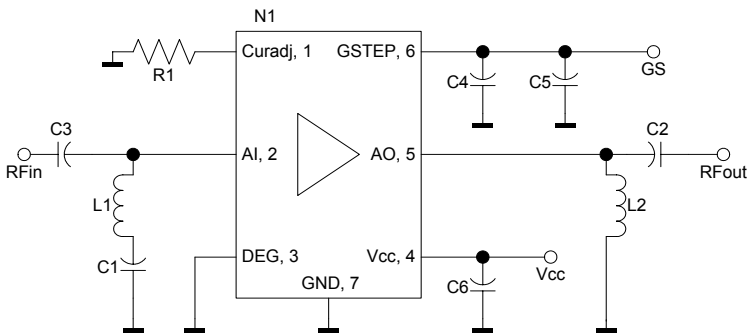

Table 3 Bill of material

Name	Value	Package	Manufacturer	Function
R1	15 kΩ	0402	various	bias resistance; set device current
L1	3.3 nH	0402	various	LF trap & input matching; L1 and C1 provide low-frequency trap to increase input IP3
L2	4.7 nH	0402	various	output matching
C1	10 nF	0402	various	LF trap for IP3 enhancement
C2	10 pF	0402	various	output DC block; optional because DC block is integrated
C3	10 pF	0402	various	input DC block
C4	10p	0402	various	control voltage filtering - OPTIONAL, depends on actual user implementation
C5	1 nF	0402	various	control voltage filtering - OPTIONAL, depends on actual user implementation
C6	1 nF	0402	various	supply filtering, depends on actual user implementation
C7		0402	various	supply filtering - OPTIONAL, depends on actual user implementation
N1	BGA619	P-TSLP-7-1	Infineon	SiGe LNA with gain-steps

The application board is made of 3 layer FR4 material (see [Figure 4](#)). The top view can be seen in [Figure 5](#) and the bottom view in [Figure 6](#). Pictures of the board can be found in [Figure 7](#) (complete board) and [Figure 8](#) (close-in photograph, where BGA619 and surrounding elements can be found in detail).

Figure 4 Application board; board construction

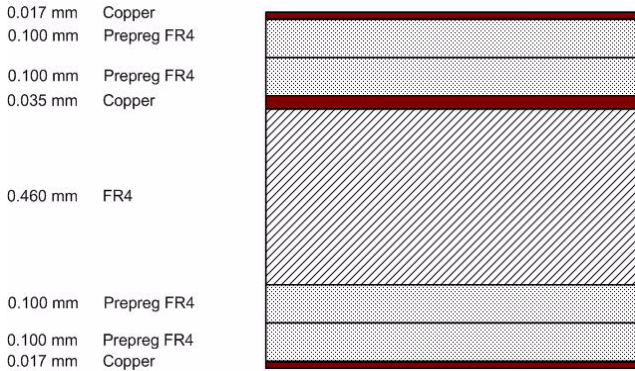

Figure 5 Application board; top view

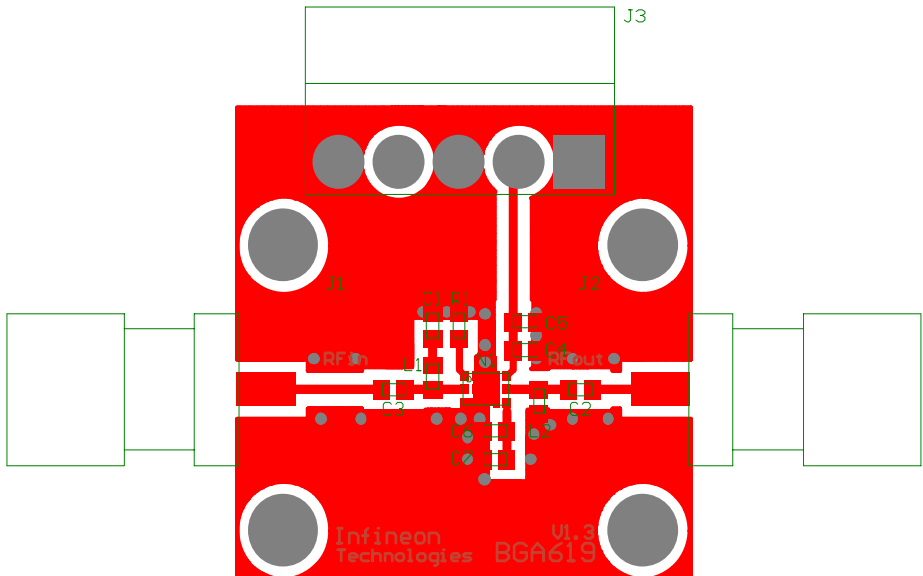

Figure 6 Application board; bottom view

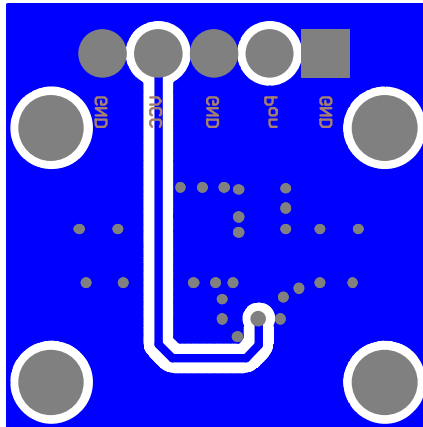

Figure 7 Foto of Application board

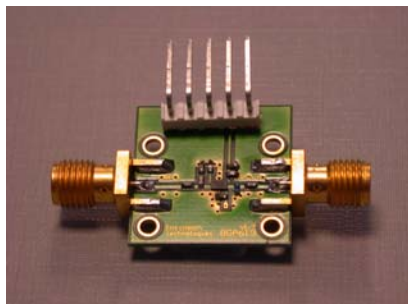
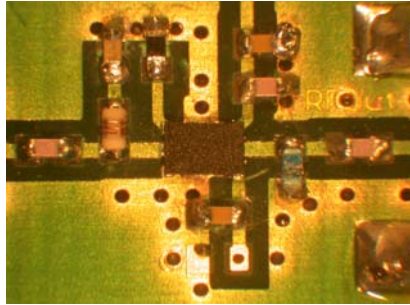

Figure 8 Scanned image of PCB, Close-In shot



The power supply connector

Figure 9 shows the pinning of the power supply connector needed for powering the test board.

Figure 9 Power Supply Connector

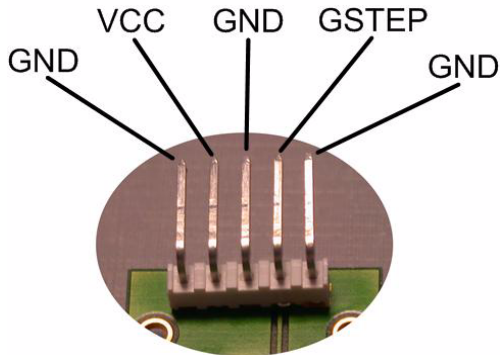

For measurement graphs please refer to the next pages.

Figure 10 Noise Figure High Gain Mode

Noise Figure $NF = f(f)$
 $V_{CC} = 2.78V, I_{CC} = 6.5mA$

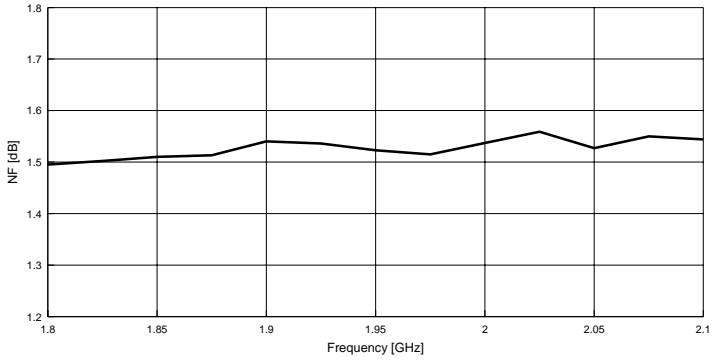

Figure 11 Gain High Gain Mode

Power Gain $|S_{21}| = f(f)$
 $V_{CC} = 2.78V, I_{CC} = 6.5mA$

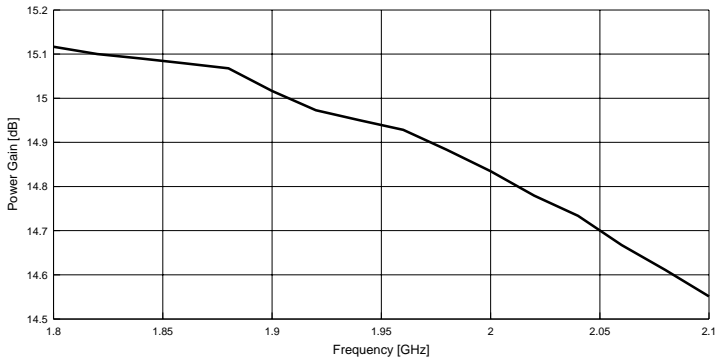

Figure 12 Return Loss High Gain Mode

Matching $|S_{11}|, |S_{22}| = f(f)$
 $V_{CC} = 2.78V, I_{CC} = 6.5mA$

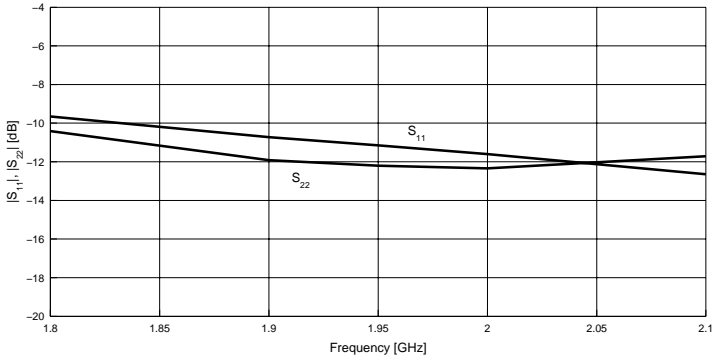

Figure 13 Reverse Isolation High Gain Mode

Reverse Isolation $|S_{12}| = f(f)$
 $V_{CC} = 2.78V, I_{CC} = 6.5mA$

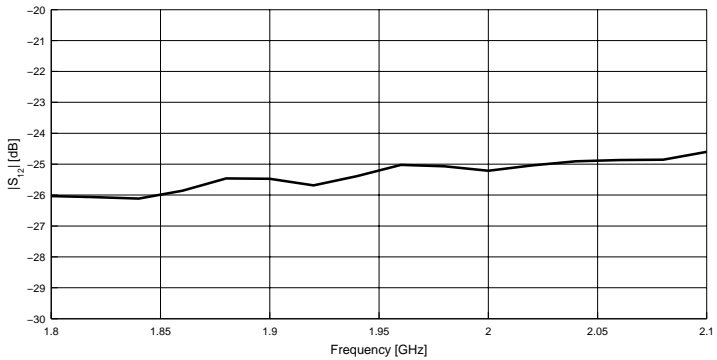

Figure 14 Noise Figure Mid Gain Mode

Noise Figure $NF = f(f)$
 $V_{CC} = 2.78V, I_{CC} = 4.5mA$

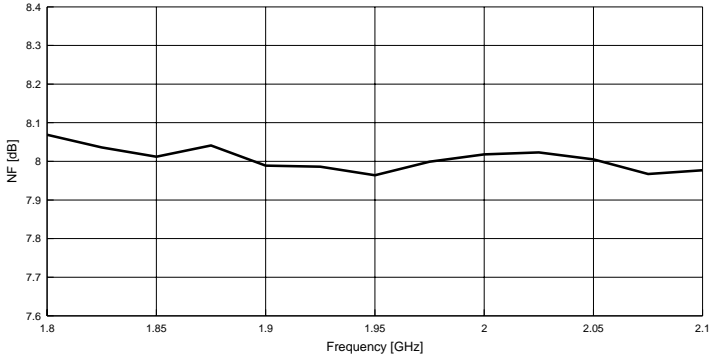

Figure 15 Gain Mid Gain Mode

Power Gain $|S_{21}| = f(f)$
 $V_{CC} = 2.78V, I_{CC} = 4.5mA$

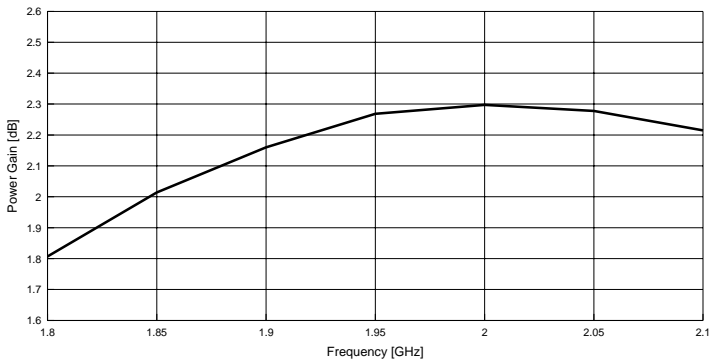

Figure 16 Return Loss Mid Gain Mode

Matching $|S_{11}|, |S_{22}| = f(f)$
 $V_{CC} = 2.78V, I_{CC} = 4.5mA$

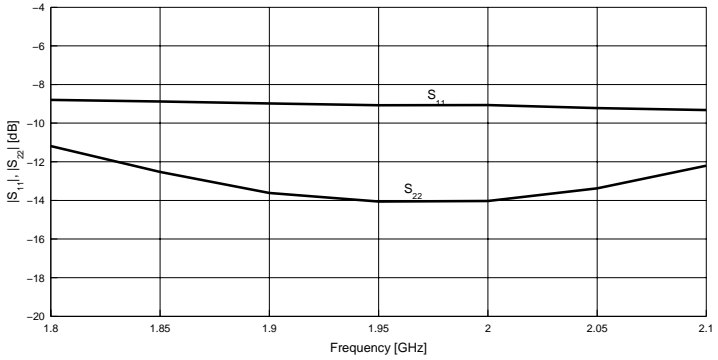

Figure 17 Reverse Isolation Mid Gain Mode

Reverse Isolation $|S_{12}| = f(f)$
 $V_{CC} = 2.78V, I_{CC} = 4.5mA$

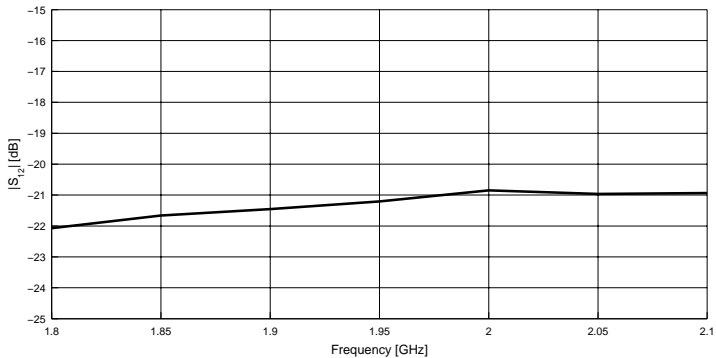

Figure 18 Noise Figure Low Gain Mode

Noise Figure $NF = f(f)$
 $V_{CC} = 2.78V, I_{CC} = 2.9mA$

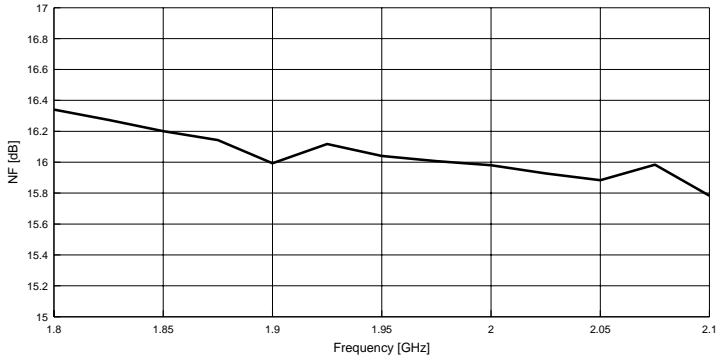

Figure 19 Gain Low Gain Mode

Power Gain $|S_{21}| = f(f)$
 $V_{CC} = 2.78V, I_{CC} = 2.9mA$

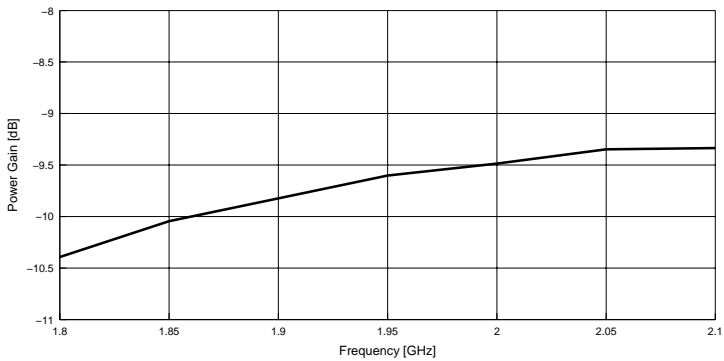

Figure 20 Return Loss Low Gain Mode

Matching $|S_{11}|, |S_{22}| = f(f)$
 $V_{CC} = 2.78V, I_{CC} = 2.9mA$

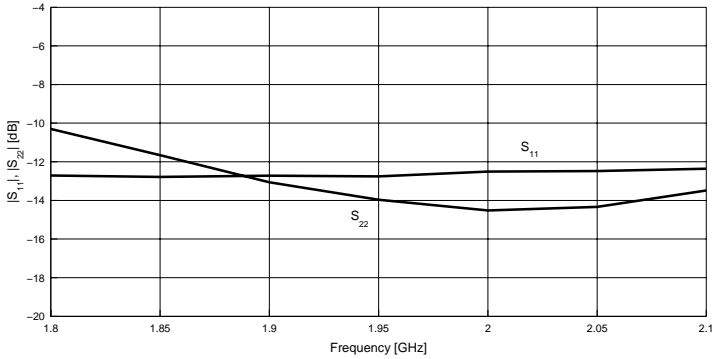
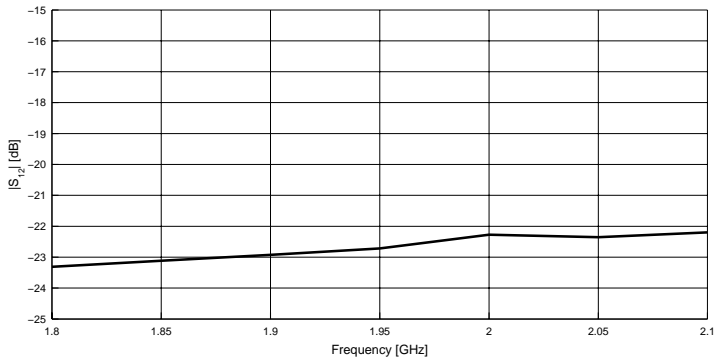

Figure 21 Reverse Isolation Low Gain Mode

Reverse Isolation $|S_{12}| = f(f)$
 $V_{CC} = 2.78V, I_{CC} = 2.9mA$



AN081

Revision History: 2004-04-19

v1.0

Previous Version:

Page	Subjects (major changes since last revision)

For questions on technology, delivery and prices please contact the Infineon Technologies Offices in Germany or the Infineon Technologies Companies and Representatives worldwide: see our webpage at <http://www.infineon.com>

Edition 2004-04-19

**Published by Infineon Technologies AG,
St.-Martin-Strasse 53,
D-81541 München**

**© Infineon Technologies AG 1999.
All Rights Reserved.**

Attention please!

The information herein is given to describe certain components and shall not be considered as warranted characteristics.

Terms of delivery and rights to technical change reserved.

We hereby disclaim any and all warranties, including but not limited to warranties of non-infringement, regarding circuits, descriptions and charts stated herein.

Infineon Technologies is an approved CECC manufacturer.

Information

For further information on technology, delivery terms and conditions and prices please contact your nearest Infineon Technologies Office in Germany or our Infineon Technologies Representatives worldwide (see address list).

Warnings

Due to technical requirements components may contain dangerous substances. For information on the types in question please contact your nearest Infineon Technologies Office.

Infineon Technologies Components may only be used in life-support devices or systems with the express written approval of Infineon Technologies, if a failure of such components can reasonably be expected to cause the failure of that life-support device or system, or to affect the safety or effectiveness of that device or system. Life support devices or systems are intended to be implanted in the human body, or to support and/or maintain and sustain and/or protect human life. If they fail, it is reasonable to assume that the health of the user or other persons may be endangered.