

4-channel PWM driver for CD, MD player

BH6519FS

● Description

The BH6519FS is a 4-channel PWM driver developed for both motor and actuator driving functions in CD and MD players. The device requires lower power consumption due to the adoption of power MOSFET in the output.

● Dimension (Units : mm)

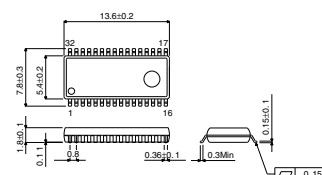

SSOP-A32

● Features

- 1) Built-in 4ch power MOSFET H bridge
- 2) PWM input
- 3) Built-in charge pump circuit for VG step-up
- 4) ON resistance 1.2Ω(Typ.)
- 5) Built-in thermal shut down circuit
- 6) Low power consumption
- 7) Small SSOP-A32 package

● Applications

CD, MD players

● Absolute Maximum Ratings (Ta=25°C)

Parameter	Symbol	Limits	Unit
H bridge supply voltage	VM	9	V
Control circuit supply voltage	VDD	9	V
Pre-driver supply voltage	VG (2pin)	12	V
Driver output current	Io	1000	mA
Power dissipation	Pd	850 *	mW
Operating temperature range	Topr	-40 ~ +85	°C
Storage temperature range	Tstg	-55 ~ +150	°C

*Derating : 6.8mW/°C for operation above Ta=25°C
70mmx70mm, t=1.6mm, glass epoxy mounting.

● Recommended Operating Conditions (Ta=25°C)

Parameter	Symbol	Min.	Typ.	Max.	Unit
H bridge supply voltage	VM *	1.6	5.0	5.5	V
Control circuit supply voltage	VDD	2.7	3.0	5.5	V
Pre-driver supply voltage	VG(2pin)	VM+3.0	10	11.5	V
Pulse input frequency	fIN	-	176.4	200	kHz

*When the built-in charge pump is not used. When it is used : 2.7V~5.5V

● Electrical characteristics

(Unless otherwise noted; $T_a=25^\circ\text{C}$, $V_M=5\text{V}$, $V_{DD}=3\text{V}$, $V_G=\text{Built-in step-up output}$, $f_{IN}=176\text{kHz}$, $R_L=8\Omega-47\mu\text{H}$)

Parameter	Symbol	Min.	Typ.	Max.	Unit	Conditions
H bridge supply current						
No input	IMST	—	410	580	μA	$V_{DD}=3\text{V}$, $V_M=5\text{V}$
Control circuit supply current						
No input	IDD1	—	100	210	μA	
Operating	IDD2	—	110	220	μA	IDD1+4CH simultaneous drive
PSB	IDD3	—	—	1	μA	
Pre drive supply voltage (Charge pump output)						
No input	VGST	8.8	9.95	12	V	
Operating	VGA	7.9	8.5	11	V	4CH simultaneous drive
Logic input characteristic						
'H' level input voltage	V_{IH}	$V_{DD}-0.6$	—	—	V	
'L' level input voltage	V_{IL}	—	—	0.6	V	
'H' level input current	I_{IH}	—	—	1	μA	
'L' level input current	I_{IL}	-1	—	—	μA	
Output ON resistance	R_{ON}	—	1.2	2.0	Ω	ON resistance (Top+bottom) $V_M=2.5\text{V}$, $V_{DD}=3\text{V}$, $V_G=10\text{V}$ (V_G is supplied outside.)
Output propagation delay time	tRISE	—	0.2	1	μsec	
	tFALL	—	0.2	1	μsec	
Minimum output pulse width	tMIN	150	—	—	nsec	Output pulse width: More than 2/3tMIN
Oscillation frequency	fosc	150	370	520	kHz	31PIN waveform monitor

*This product is not designed for protection against radioactive rays.

● Block Diagram

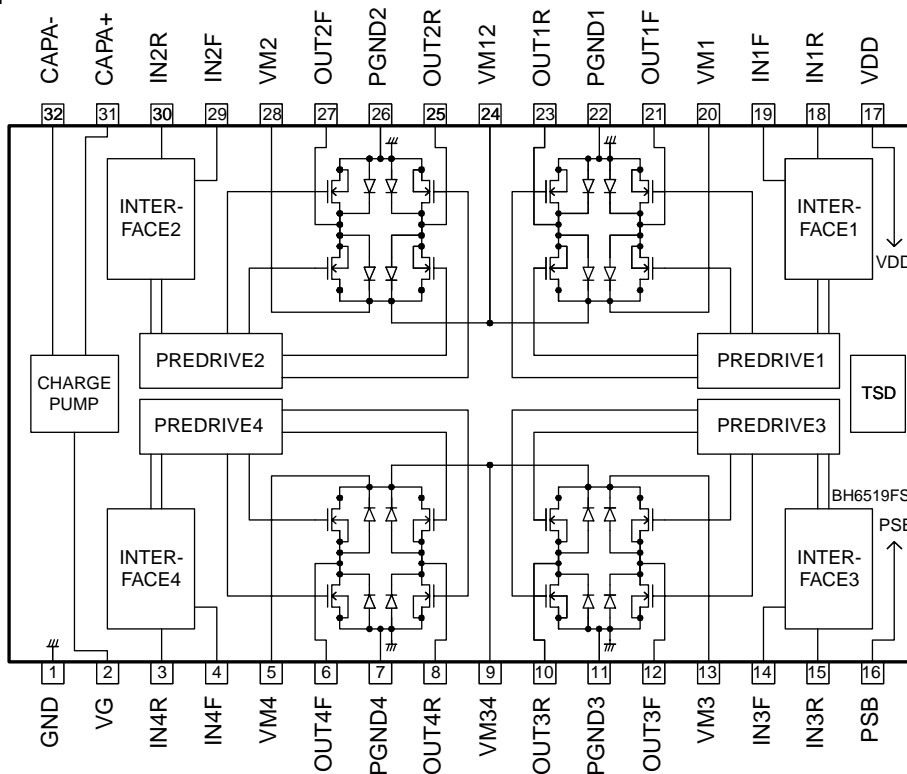

Notes

- No technical content pages of this document may be reproduced in any form or transmitted by any means without prior permission of ROHM CO.,LTD.
- The contents described herein are subject to change without notice. The specifications for the product described in this document are for reference only. Upon actual use, therefore, please request that specifications to be separately delivered.
- Application circuit diagrams and circuit constants contained herein are shown as examples of standard use and operation. Please pay careful attention to the peripheral conditions when designing circuits and deciding upon circuit constants in the set.
- Any data, including, but not limited to application circuit diagrams information, described herein are intended only as illustrations of such devices and not as the specifications for such devices. ROHM CO.,LTD. disclaims any warranty that any use of such devices shall be free from infringement of any third party's intellectual property rights or other proprietary rights, and further, assumes no liability of whatsoever nature in the event of any such infringement, or arising from or connected with or related to the use of such devices.
- Upon the sale of any such devices, other than for buyer's right to use such devices itself, resell or otherwise dispose of the same, no express or implied right or license to practice or commercially exploit any intellectual property rights or other proprietary rights owned or controlled by
- ROHM CO., LTD. is granted to any such buyer.
- Products listed in this document use silicon as a basic material.
Products listed in this document are no antiradiation design.

The products listed in this document are designed to be used with ordinary electronic equipment or devices (such as audio visual equipment, office-automation equipment, communications devices, electrical appliances and electronic toys).

Should you intend to use these products with equipment or devices which require an extremely high level of reliability and the malfunction of which would directly endanger human life (such as medical instruments, transportation equipment, aerospace machinery, nuclear-reactor controllers, fuel controllers and other safety devices), please be sure to consult with our sales representative in advance.

About Export Control Order in Japan

Products described herein are the objects of controlled goods in Annex 1 (Item 16) of Export Trade Control Order in Japan.

In case of export from Japan, please confirm if it applies to "objective" criteria or an "informed" (by MITI clause) on the basis of "catch all controls for Non-Proliferation of Weapons of Mass Destruction.