



Ultra Low Power/Voltage CMOS SRAM 64K X 16 bit

BS616UV1010

FEATURES

- Ultra low operation voltage : 1.8 ~ 3.6V
- Ultra low power consumption :
 - V_{cc} = 2.0V C-grade : 10mA (Max.) operating current
I-grade : 15mA (Max.) operating current
0.01uA (Typ.) CMOS standby current
 - V_{cc} = 3.0V C-grade : 15mA (Max.) operating current
I-grade : 20mA (Max.) operating current
0.02uA (Typ.) CMOS standby current
- High speed access time :
 - 15 150ns (Max.) at V_{cc} = 3.0V
- Input levels are CMOS-compatible
- Automatic power down when chip is deselected
- Three state outputs and TTL compatible
- Fully static operation
- Data retention supply voltage as low as 1.5V
- Easy expansion with \overline{CE} and \overline{OE} options
- I/O Configuration x8/x16 selectable by \overline{LB} and \overline{UB} pin

DESCRIPTION

The BS616UV1010 is a high performance, ultra low power CMOS Static Random Access Memory organized as 65,536 words by 16 bits and operates from a wide range of 1.8V to 3.6V supply voltage. Advanced CMOS technology and circuit techniques provide both high speed and low power features with a typical CMOS standby current of 0.01uA and maximum access time of 150ns in 2V operation. Easy memory expansion is provided by an active LOW chip enable (\overline{CE}) and active LOW output enable (\overline{OE}) and three-state output drivers. The BS616UV1010 has an automatic power down feature, reducing the power consumption significantly when chip is deselected. The BS616UV1010 is available in the JEDEC standard 44-pin TSOP Type II and 48-pin mini-BGA.

PRODUCT FAMILY

PRODUCT FAMILY	OPERATING TEMPERATURE	V _{cc} RANGE	SPEED (ns)	POWER DISSIPATION				PKG TYPE
				STANDBY (I _{ccsB1, Max})		Operating (I _{cc, Max})		
				V _{cc} =3.0V	V _{cc} =3.0V	V _{cc} =2.0V	V _{cc} =3.0V	
BS616UV1010EC	+0°C to +70°C	1.8V ~ 3.6V	150	0.5uA	0.3uA	15mA	10mA	TSOP2-44
BS616UV1010AC								BGA-48-0608
BS616UV1010EI	-40°C to +85°C	1.8V ~ 3.6V	150	1.5uA	1uA	20mA	15mA	TSOP2-44
BS616UV1010AI								BGA-48-0608

PIN CONFIGURATIONS

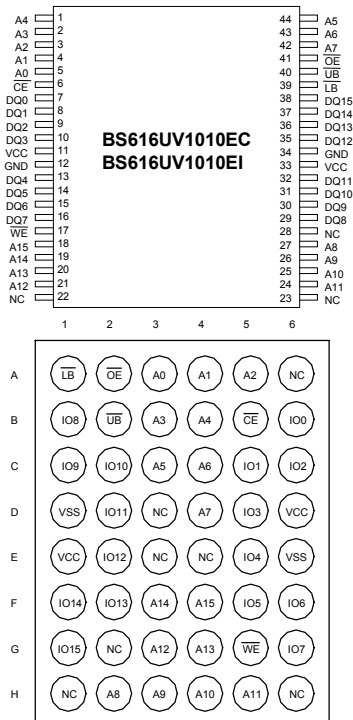

BLOCK DIAGRAM

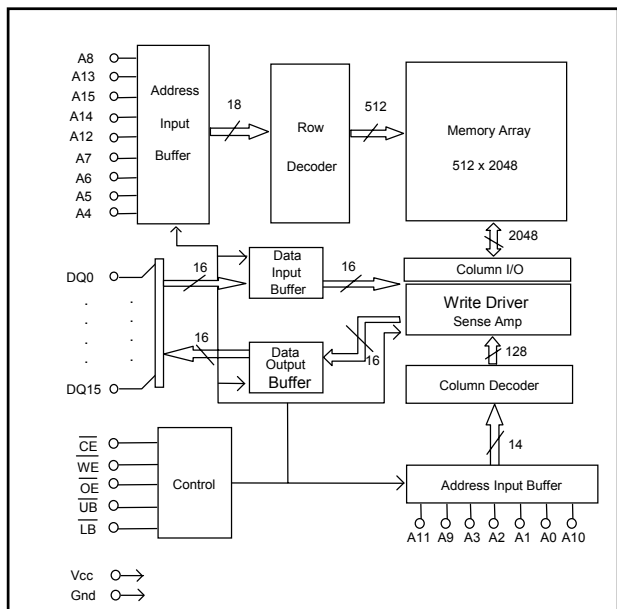

Brilliance Semiconductor Inc. reserves the right to modify document contents without notice.

■ PIN DESCRIPTIONS

Name	Function
A0-A15 Address Input	These 16 address input select one of the 65,536 x 16-bit words in the RAM.
\overline{CE} Chip Enable Input	\overline{CE} is active LOW. Chip enables must be active to read from or write to the device. If chip enable is not active, the device is deselected and is in a standby power mode. The DQ pins will be in the high impedance state when the device is deselected.
\overline{WE} Write Enable Input	The write enable input is active LOW and controls read and write operations. With the chip selected, when \overline{WE} is HIGH and \overline{OE} is LOW, output data will be present on the DQ pins; when \overline{WE} is LOW, the data present on the DQ pins will be written into the selected memory location.
\overline{OE} Output Enable Input	The output enable input is active LOW. If the output enable is active while the chip is selected and the write enable is inactive, data will be present on the DQ pins and they will be enabled. The DQ pins will be in the high impedance state when \overline{OE} is inactive.
\overline{LB} and \overline{UB} Data Byte Control Input	Lower byte and upper byte data input/output control pins.
DQ0 - DQ15 Data Input/Output Ports	These 16 bi-directional ports are used to read data from or write data into the RAM.
Vcc	Power Supply
Gnd	Ground

■ TRUTH TABLE

MODE	\overline{CE}	\overline{WE}	\overline{OE}	\overline{LB}	\overline{UB}	DQ0~DQ7	DQ8~DQ15	Vcc CURRENT
Not selected (Power Down)	H	X	X	X	X	High Z	High Z	I_{CCSB}, I_{CCSB1}
Output Disabled	L	H	H	X	X	High Z	High Z	I_{CC}
Read	L	H	L	L	L	Dout	Dout	I_{CC}
				H	L	High Z	Dout	I_{CC}
				L	H	Dout	High Z	I_{CC}
Write	L	L	X	L	L	Din	Din	I_{CC}
				H	L	X	Din	I_{CC}
				L	H	Din	X	I_{CC}

■ ABSOLUTE MAXIMUM RATINGS⁽¹⁾

SYMBOL	PARAMETER	RATING	UNITS
V _{TERM}	Terminal Voltage with Respect to GND	-0.5 to V _{CC} +0.5	V
T _{BIAS}	Temperature Under Bias	-40 to +125	°C
T _{STG}	Storage Temperature	-60 to +150	°C
P _T	Power Dissipation	1.0	W
I _{OUT}	DC Output Current	20	mA

1. Stresses greater than those listed under ABSOLUTE MAXIMUM RATINGS may cause permanent damage to the device. This is a stress rating only and functional operation of the device at these or any other conditions above those indicated in the operational sections of this specification is not implied. Exposure to absolute maximum rating conditions for extended periods may affect reliability.

■ OPERATING RANGE

RANGE	AMBIENT TEMPERATURE	V _{CC}
Commercial	0°C to +70°C	1.8V ~ 3.6V
Industrial	-40°C to +85°C	1.8V ~ 3.6V

■ CAPACITANCE ⁽¹⁾ (TA = 25°C, f = 1.0 MHz)

SYMBOL	PARAMETER	CONDITIONS	MAX.	UNIT
C _{IN}	Input Capacitance	V _{IN} =0V	6	pF
C _{DQ}	Input/Output Capacitance	V _{I/O} =0V	8	pF

1. This parameter is guaranteed and not tested.

■ DC ELECTRICAL CHARACTERISTICS (TA = 0°C to + 70°C)

PARAMETER NAME	PARAMETER	TEST CONDITIONS	MIN.	TYP. ⁽¹⁾	MAX.	UNITS
V _{IL}	Guaranteed Input Low Voltage ⁽²⁾	V _{CC} =2.0V V _{CC} =3.0V	-0.5	--	0.6 0.8	V
V _{IH}	Guaranteed Input High Voltage ⁽²⁾		V _{CC} =2.0V V _{CC} =3.0V	1.4 2.0	--	V _{CC} +0.2
I _{IL}	Input Leakage Current	V _{CC} = Max, V _{IN} = 0V to V _{CC}	--	--	1	µA
I _{OL}	Output Leakage Current	V _{CC} = Max, $\overline{CE} = V_{IH}$, or $\overline{OE} = V_{IH}$, V _{IO} = 0V to V _{CC}	--	--	1	µA
V _{OL}	Output Low Voltage	V _{CC} = Max, I _{OL} = 1mA	--	--	0.4	V
V _{OH}	Output High Voltage		V _{CC} = Min, I _{OH} = -0.5mA	1.6 2.4	--	--
I _{CC}	Operating Power Supply Current	$\overline{CE} = V_{IL}$, I _{DQ} = 0mA, F = F _{max} ⁽³⁾	--	--	10 15	mA
I _{CCSB}	Standby Current-TTL		V _{CC} =2.0V V _{CC} =3.0V	--	--	0.5 1
I _{CCSB1}	Standby Current-CMOS	$\overline{CE} \geq V_{CC}-0.2V$, V _{IN} \geq V _{CC} - 0.2V or V _{IN} \leq 0.2V	--	0.01	0.3	µA
			V _{CC} =2.0V V _{CC} =3.0V	--	0.02	

1. Typical characteristics are at TA = 25°C.

2. These are absolute values with respect to device ground and all overshoots due to system or tester noise are included.

3. F_{max} = 1/t_{RC}.

■ DATA RETENTION CHARACTERISTICS (TA = 0°C to + 70°C)

SYMBOL	PARAMETER	TEST CONDITIONS	MIN.	TYP. ⁽¹⁾	MAX.	UNITS
V _{DR}	V _{CC} for Data Retention	$\overline{CE} \geq V_{CC} - 0.2V$ V _{IN} \geq V _{CC} - 0.2V or V _{IN} \leq 0.2V	1.5	--	--	V
I _{CCDR}	Data Retention Current	$\overline{CE} \geq V_{CC} - 0.2V$ V _{IN} \geq V _{CC} - 0.2V or V _{IN} \leq 0.2V	--	0.01	0.2	µA
t _{CDR}	Chip Deselect to Data Retention Time	See Retention Waveform	0	--	--	ns
t _R	Operation Recovery Time		T _{RC} ⁽²⁾	--	--	--



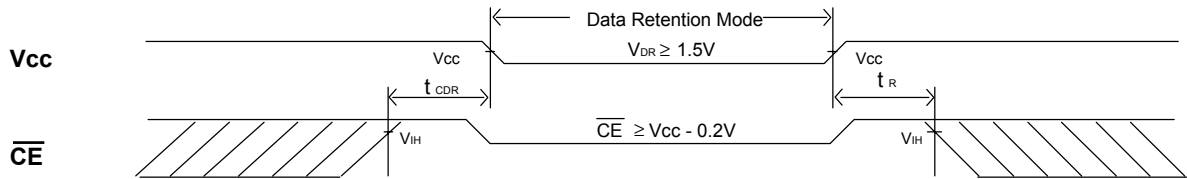

1. V_{CC} = 1.5V, T_A = + 25°C

2. t_{RC} = Read Cycle Time

■ LOW V_{CC} DATA RETENTION WAVEFORM (\overline{CE} Controlled)

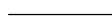
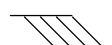
■ AC TEST CONDITIONS

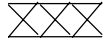
Input Pulse Levels	$V_{CC}/0V$
Input Rise and Fall Times	5ns
Input and Output Timing Reference Level	$0.5V_{CC}$

■ KEY TO SWITCHING WAVEFORMS

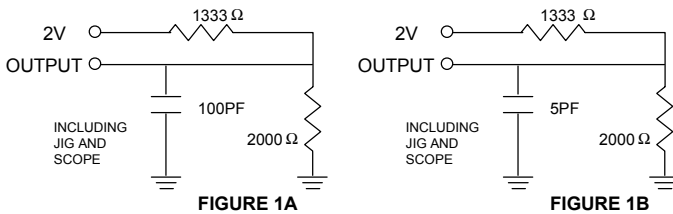
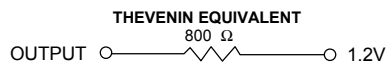
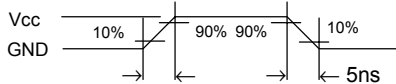
WAVEFORM	INPUTS	OUTPUTS
	MUST BE STEADY	MUST BE STEADY
	MAY CHANGE FROM H TO L	WILL BE CHANGE FROM H TO L
	MAY CHANGE FROM L TO H	WILL BE CHANGE FROM L TO H
	DON'T CARE: ANY CHANGE PERMITTED	CHANGE: STATE UNKNOWN
	DOES NOT APPLY	CENTER LINE IS HIGH IMPEDANCE "OFF" STATE

■ AC TEST LOADS AND WAVEFORMS

FIGURE 1A
FIGURE 1B

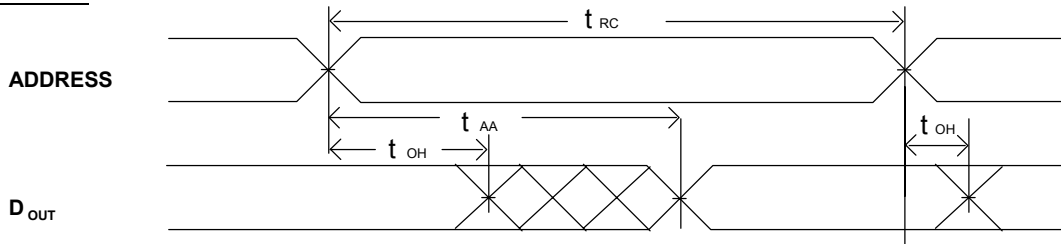
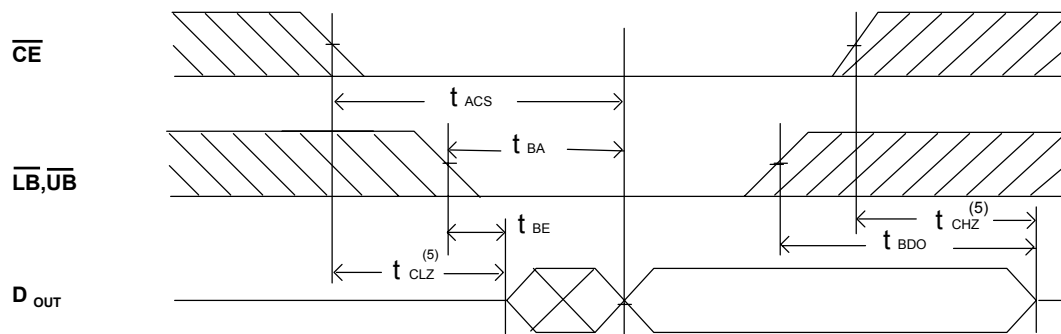
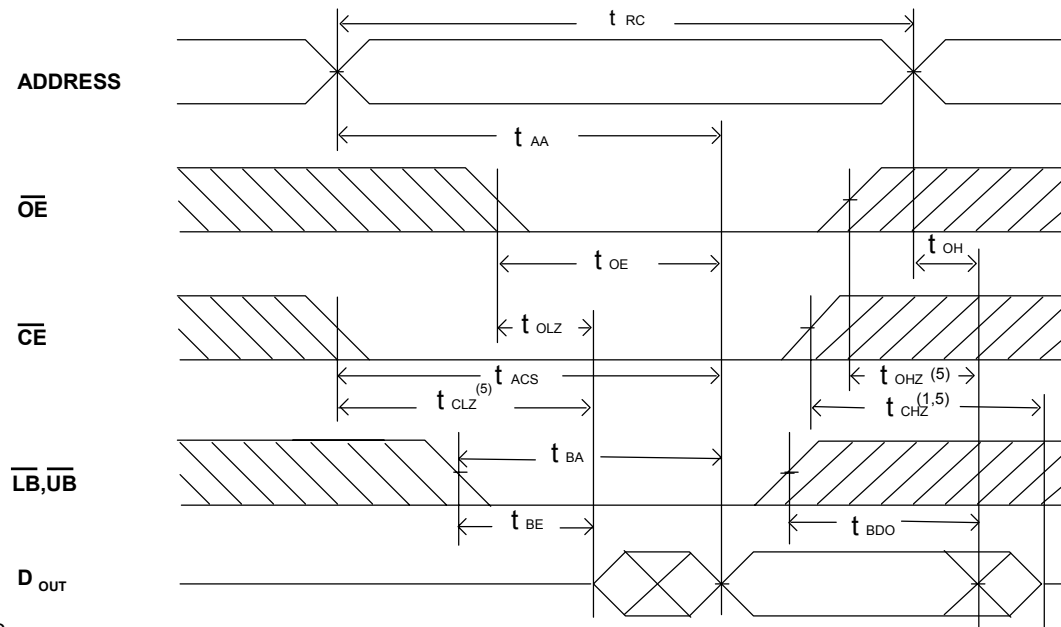
THEVENIN EQUIVALENT

FIGURE 2
■ AC ELECTRICAL CHARACTERISTICS ($T_A = 0^\circ C$ to $+70^\circ C$, $V_{CC} = 2.0V$)
READ CYCLE

JEDEC PARAMETER NAME	PARAMETER NAME	DESCRIPTION	BS616UV1010-15			UNIT
			MIN.	TYP.	MAX.	
t_{AVAX}	t_{RC}	Read Cycle Time	150	--	--	ns
t_{AVQV}	t_{AA}	Address Access Time	--	--	150	ns
t_{ELQV}	t_{ACS}	Chip Select Access Time (\overline{CE})	--	--	150	ns
t_{BA}	t_{BA}	Data Byte Control Access Time ($\overline{LB}, \overline{UB}$)	--	--	150	ns
t_{GLQV}	t_{OE}	Output Enable to Output Valid	--	--	80	ns
t_{ELQX}	t_{CLZ}	Chip Select to Output Low Z (\overline{CE})	15	--	--	ns
t_{BE}	t_{BE}	Data Byte Control to Output Low Z ($\overline{LB}, \overline{UB}$)	15	--	--	ns
t_{GLQX}	t_{OLZ}	Output Enable to Output in Low Z	15	--	--	ns
t_{EHQZ}	t_{CHZ}	Chip Deselect to Output in High Z (\overline{CE})	0	--	45	ns
t_{BDO}	t_{BDO}	Data Byte Control to Output High Z ($\overline{LB}, \overline{UB}$)	0	--	40	ns
t_{GHQZ}	t_{OHZ}	Output Disable to Output in High Z	0	--	40	ns
t_{AXOX}	t_{OH}	Output Disable to Output Address Change	15	--	--	ns

SWITCHING WAVEFORMS (READ CYCLE)
READ CYCLE1 (1,2,4)

READ CYCLE2 (1,3,4)

READ CYCLE3 (1,4)

NOTES:

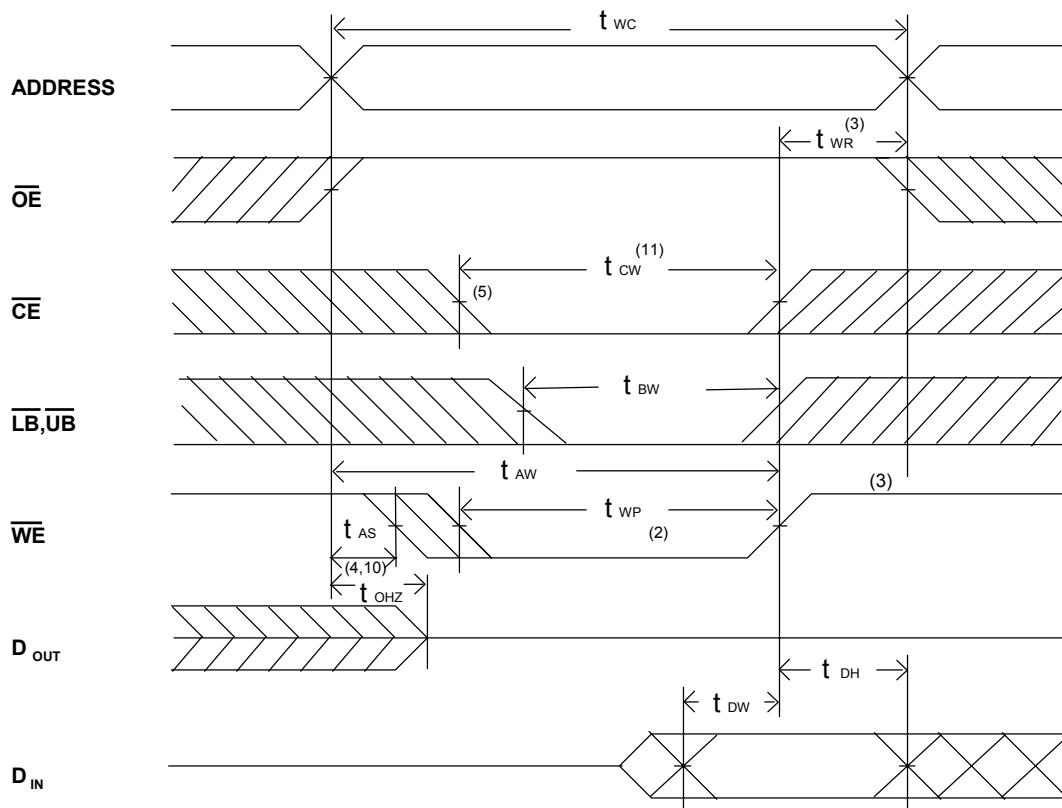
1. WE is high for read Cycle.
2. Device is continuously selected when $\overline{CE} = V_{IL}$.
3. Address valid prior to or coincident with \overline{CE} transition low.
4. $\overline{OE} = V_{IL}$.
5. Transition is measured $\pm 500\text{mV}$ from steady state with $C_L = 5\text{pF}$ as shown in Figure 1B. The parameter is guaranteed but not 100% tested.

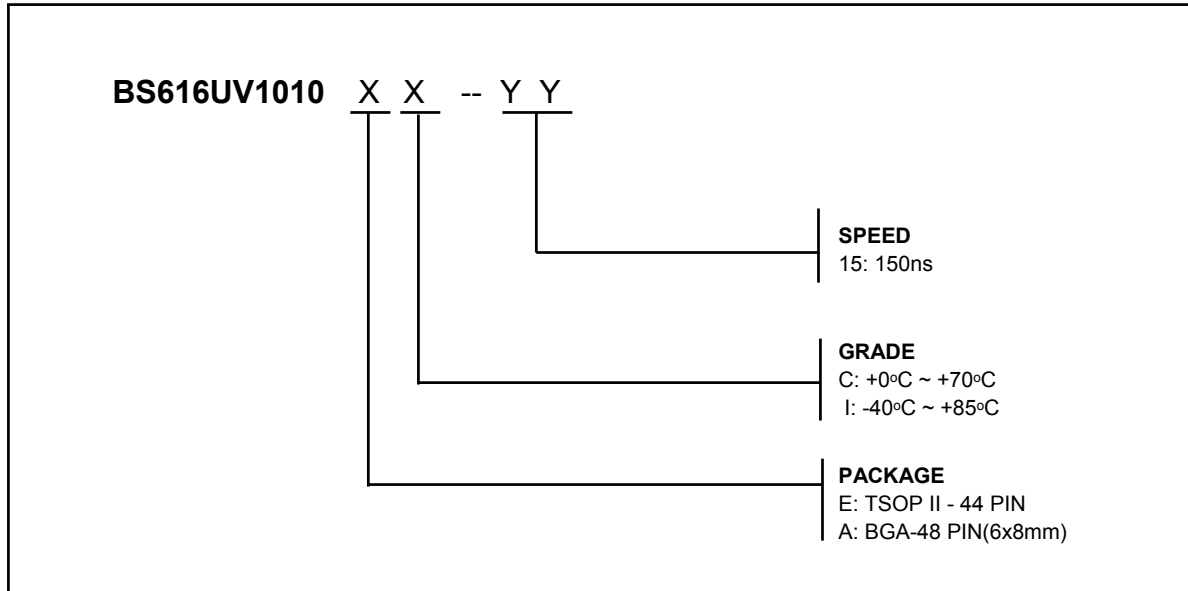
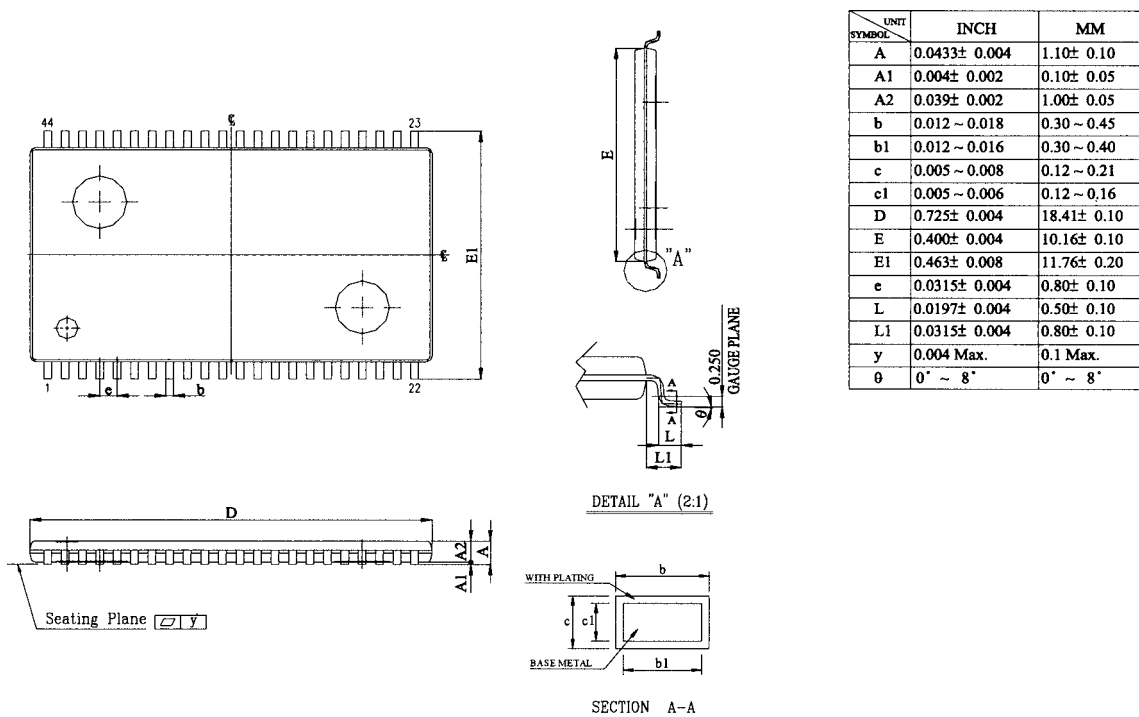
■ AC ELECTRICAL CHARACTERISTICS (TA = 0°C to + 70°C, Vcc = 2.0V)
WRITE CYCLE

JEDEC PARAMETER NAME	PARAMETER NAME	DESCRIPTION	BS616UV1010-15			UNIT
			MIN.	TYP.	MAX.	
t_{AVAX}	t_{WC}	Write Cycle Time	150	--	--	ns
t_{E1LWH}	t_{CW}	Chip Select to End of Write	150	--	--	ns
t_{AVWL}	t_{AS}	Address Setup Time	0	--	--	ns
t_{AVWH}	t_{AW}	Address Valid to End of Write	150	--	--	ns
t_{WLWH}	t_{WP}	Write Pulse Width	80	--	--	ns
t_{WHAX}	t_{WR}	Write recovery Time $(\overline{CE}, \overline{WE})$	0	--	--	ns
t_{BW}	t_{BW}	Date Byte Control to End of Write $(\overline{LB}, \overline{UB})$	70	--	--	ns
t_{WLQZ}	t_{WHZ}	Write to Output in High Z	0	--	40	ns
t_{DVWH}	t_{DW}	Data to Write Time Overlap	40	--	--	ns
t_{WHDX}	t_{DH}	Data Hold from Write Time	0	--	--	ns
t_{GHQZ}	t_{OHZ}	Output Disable to Output in High Z	0	--	40	ns
t_{WHOX}	t_{OW}	End of Write to Output Active	5	--	--	ns

■ SWITCHING WAVEFORMS (WRITE CYCLE)
WRITE CYCLE1⁽¹⁾

ORDERING INFORMATION

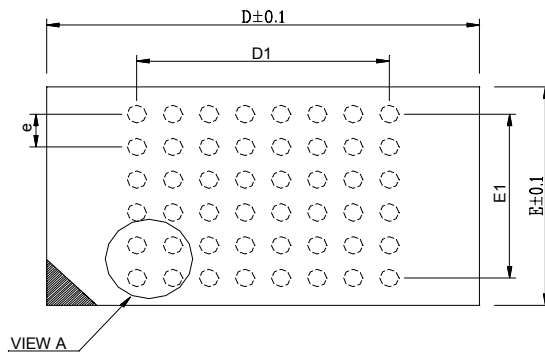
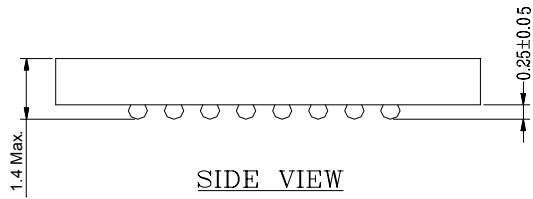
PACKAGE DIMENSIONS

TSOP2-44

■ PACKAGE DIMENSIONS (continued)

48 mini-BGA (6 x 8)

NOTES:

- 1: CONTROLLING DIMENSIONS ARE IN MILLIMETERS.
- 2: PIN#1 DOT MARKING BY LASER OR PAD PRINT.
- 3: SYMBOL "N" IS THE NUMBER OF SOLDER BALLS.

BALL PITCH e = 0.75				
D	E	N	D1	E1
8.0	6.0	48	5.25	3.75

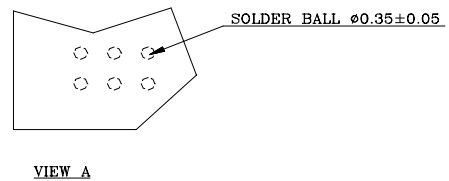

REVISION HISTORY

Revision	Description	Date	Note
2.2	2001 Data Sheet release	Apr. 15, 2001	