

## KV5x Data Sheet

200/220 MHz Cortex-M7 based MCU for Real-time, high performance connected control

The Kinetis KV5x family of MCU is a high-performance solution offering exceptional precision, sensing, and control targeting Motor Control, Industrial Drives and Automation, and Power Conversion. Apart from the high performance Cortex-M7 core, it features top notch real time control peripherals such as high resolution pulse-width modulation (PWM) with 284 ps resolution, 4 Fast 12-bit ADCs with 5 MSps, up to 44 PWM channels for supporting multi-motor systems. It also comes with multiple communication peripherals including 3 FlexCAN modules, optional Ethernet Communications, and multiple UART, SPI, and I2C modules. The KV5x is supported by a comprehensive enablement suite from Freescale and third-party resources including reference designs, software libraries, and motor configuration tools.

**MKV56FxxxCxx22**  
**MKV56FxxxVxx20**  
**MKV58FxxxCxx22**  
**MKV58FxxxVxx20**

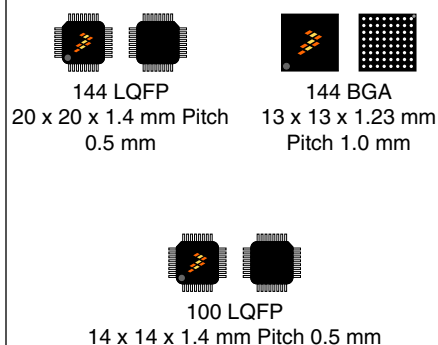

### Core

- ARM® Cortex®-M7 core up to 220 MHz with single precision Floating Point Unit (FPU)

### Memories

- Up to 1 MB program flash memory
- Up to 256 KB RAM
- External memory interface (FlexBus)

### System peripherals

- 32-channel DMA controller
- Low-leakage wakeup unit
- SWD debug interface
- Advanced independent clocked watchdog
- JTAG debug interface

### Clocks

- 32 to 40 kHz or 3 to 32 MHz crystal oscillator
- MCG with FLL and PLL referencing internal or external reference clock

### Operating Characteristics

- Voltage range: 1.71 to 3.6 V
- Temperature range: -40 to 105 °C

### Human-machine interface

- General-purpose input/output

### Communication interfaces

- Six UART/FlexSCI modules with programmable 8- or 9-bit data format
- Three 16-bit SPI modules
- Two I2C modules
- Three FlexCAN modules
- Ethernet Module (Optional)

### Analog Modules

- Four 12-bit SAR High Speed ADCs with 5 MSPS sample rate
- One 16-bit ADC
- Four CMPs with a 6-bit DAC and programmable reference input
- One 12-bit DAC

### Timers

- Two eFlexPWM with 4 sub-modules, with 12 PWM outputs, one eFlexPWM module with less than 285 ps resolution provided by nano-edge module.
- Two 8-channel FlexTimers (FTM0 and FTM3)
- Two 2-channel FlexTimers (FTM1 and FTM2)
- Four Periodic interrupt timers (PIT)
- Two Programmable Delay Blocks (PDB)
- Quadrature Encoder/Decoder (ENC)

### Security and integrity modules

- Hardware CRC module to support fast cyclic redundancy checks
- External Watchdog Monitor (EWM)
- True Random Number Generator (TRNG)
- Memory mapped Cryptographic Acceleration Unit (MMCAU)
- Advanced Watchdog (WDOG) timer modules

### Orderable part numbers summary<sup>1</sup>

Freescal e part number	CPU frequency (MHz)	Ambient operating temperature (°C)	Package	Flash/ SRAM	Ethernet	CAN	GPIO
MKV58F1M0CMD22 <sup>2</sup>	220	85	144 MAPBGA	1 MB/256 KB	Yes	3	111
MKV58F1M0CLQ22	220	85	144 LQFP	1 MB/256 KB	Yes	3	111
MKV58F1M0CLL22	220	85	100 LQFP	1 MB/256 KB	Yes	3	74
MKV56F1M0CMD22 <sup>2</sup>	220	85	144 MAPBGA	1 MB/256 KB	No	2	111
MKV56F1M0CLQ22	220	85	144 LQFP	1 MB/256 KB	No	2	111
MKV56F1M0CLL22	220	85	100 LQFP	1 MB/256 KB	No	2	74
MKV58F512CMD22 <sup>2</sup>	220	85	144 MAPBGA	512 KB/128 KB	Yes	3	111
MKV58F512CLQ22	220	85	144 LQFP	512 KB/128 KB	Yes	3	111
MKV58F512CLL22	220	85	100 LQFP	512 KB/128 KB	Yes	3	74
MKV56F512CMD22 <sup>2</sup>	220	85	144 MAPBGA	512 KB/128 KB	No	2	111
MKV56F512CLQ22	220	85	144 LQFP	512 KB/128 KB	No	2	111
MKV56F512CLL22	220	85	100 LQFP	512 KB/128 KB	No	2	74
MKV58F1M0VLQ20	200	105	144 LQFP	1 MB/256 KB	Yes	3	111
MKV58F1M0VLL20	200	105	100 LQFP	1 MB/256 KB	Yes	3	74
MKV56F1M0VLQ20	200	105	144 LQFP	1 MB/256 KB	No	2	111
MKV56F1M0VLL20	200	105	100 LQFP	1 MB/256 KB	No	2	74
MKV58F512VLQ20	200	105	144 LQFP	512 KB/128 KB	Yes	3	111

Table continues on the next page...

### Orderable part numbers summary<sup>1</sup> (continued)

Freescal e part number	CPU frequency (MHz)	Ambient operating temperature (°C)	Package	Flash/ SRAM	Ethernet	CAN	GPIO
MKV58F512VLL20	200	105	100 LQFP	512 KB/128 KB	Yes	3	74
MKV56F512VLQ20	200	105	144 LQFP	512 KB/128 KB	No	2	111
MKV56F512VLL20	200	105	100 LQFP	512 KB/128 KB	No	2	74

1. To confirm current availability of orderable part numbers, go to <http://www.freescale.com> and perform a part number search.
2. The 144-pin MAPBGA package for this product is not yet available. However, it is included in a Package Your Way program for Kinetis MCUs. Visit [freescale.com/KPYW](http://www.freescale.com/KPYW) for more details.

### Related Resources

Type	Description	Resource
Selector Guide	The Freescale Solution Advisor is a web-based tool that features interactive application wizards and a dynamic product selector.	<a href="#">Solution Advisor</a>
Reference Manual	The Reference Manual contains a comprehensive description of the structure and function (operation) of a device.	<a href="#">KV5XP144M220RM<sup>1</sup></a>
Data Sheet	The Data Sheet includes electrical characteristics and signal connections.	<a href="#">KV5XP144M220<sup>1</sup></a>
Chip Errata	The chip mask set Errata provides additional or corrective information for a particular device mask set.	<a href="#">KINETIS_V_0N86P<sup>1</sup></a>
Package drawing	Package dimensions are provided in package drawings.	<ul style="list-style-type: none"> <li>• MAPBGA 144-pin: <a href="#">98ASA00222D<sup>1</sup></a></li> <li>• LQFP 144-pin: <a href="#">98ASS23177W<sup>1</sup></a></li> <li>• LQFP 100-pin: <a href="#">98ASS23308W<sup>1</sup></a></li> </ul>

1. To find the associated resource, go to <http://www.freescale.com> and perform a search using this term.

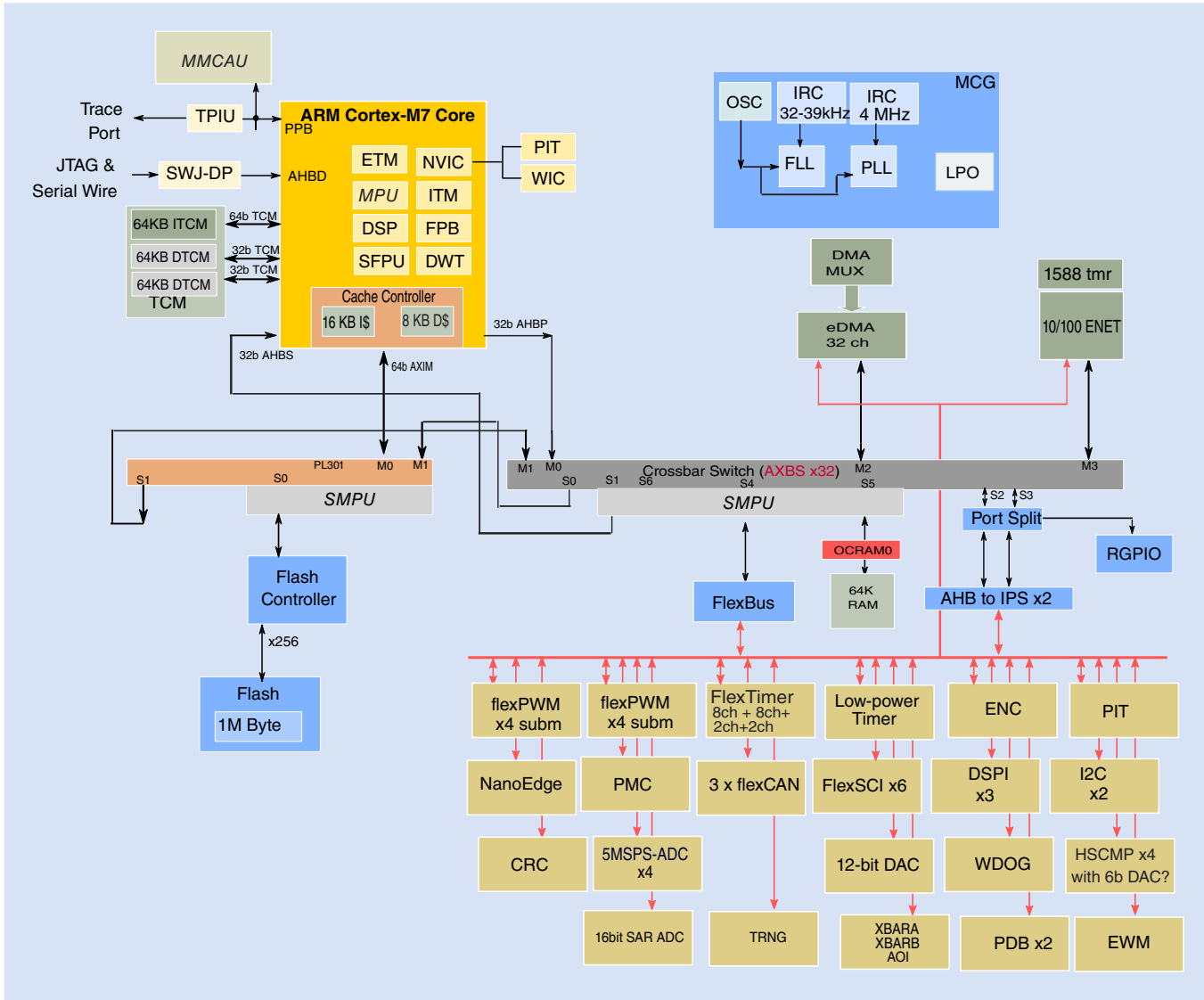

Figure 1. KV5x block diagram

# Table of Contents

1 Ratings.....	6	3.7.2 ADC electrical specifications.....	35
1.1 Thermal handling ratings.....	6	3.7.3 CMP and 6-bit DAC electrical specifications.....	40
1.2 Moisture handling ratings.....	6	3.7.4 12-bit DAC electrical characteristics.....	41
1.3 ESD handling ratings.....	6	3.8 Timers.....	44
1.4 Voltage and current operating ratings.....	6	3.9 Communication interfaces.....	44
2 General.....	7	3.9.1 CAN switching specifications.....	44
2.1 AC electrical characteristics.....	7	3.9.2 Ethernet switching specifications.....	44
2.2 Nonswitching electrical specifications.....	7	3.9.3 DSPI switching specifications (limited voltage range).....	46
2.2.1 Operating Requirements.....	7	3.9.4 DSPI switching specifications (full voltage range).....	48
2.2.2 HVD, LVD, and POR operating requirements.....	8	3.9.5 I2C.....	50
2.2.3 PORT Voltage and current operating behaviors.....	9	3.9.6 UART.....	50
2.2.4 Power mode transition operating behaviors.....	10	4 Dimensions.....	50
2.2.5 Power consumption operating behaviors.....	11	4.1 Obtaining package dimensions.....	50
2.2.6 EMC radiated emissions operating behaviors.....	14	5 Pinouts and Packaging.....	51
2.2.7 Designing with radiated emissions in mind.....	15	5.1 KV5x Signal Multiplexing and Pin Assignments.....	51
2.2.8 Capacitance attributes.....	15	5.2 KV5x Pinouts.....	59
2.3 Switching specifications.....	15	6 Ordering parts.....	62
2.3.1 Typical device clock specifications.....	15	6.1 Determining valid orderable parts.....	62
2.3.2 General switching specifications.....	16	7 Part identification.....	63
2.4 Thermal specifications.....	17	7.1 Description.....	63
2.4.1 Thermal operating requirements.....	17	7.2 Format.....	63
2.4.2 Thermal attributes.....	18	7.3 Fields.....	63
3 Peripheral operating requirements and behaviors.....	18	7.4 Example.....	64
3.1 Core modules.....	18	8 Terminology and guidelines.....	64
3.1.1 SWD Electricals .....	18	8.1 Definition: Operating requirement.....	64
3.1.2 Debug trace timing specifications.....	20	8.2 Definition: Operating behavior.....	64
3.1.3 JTAG electricals.....	21	8.3 Definition: Attribute.....	65
3.2 System modules.....	24	8.4 Definition: Rating.....	65
3.3 Clock modules.....	24	8.5 Result of exceeding a rating.....	65
3.3.1 MCG specifications.....	24	8.6 Relationship between ratings and operating requirements.....	66
3.3.2 Oscillator electrical specifications.....	26	8.7 Guidelines for ratings and operating requirements.....	66
3.4 Memories and memory interfaces.....	28	8.8 Definition: Typical value.....	67
3.4.1 Flash (FTFE) electrical specifications.....	28	8.9 Typical Value Conditions.....	68
3.5 Flexbus switching specifications.....	30	9 Revision History.....	68
3.6 Security and integrity modules.....	32		
3.7 Analog.....	32		
3.7.1 12-bit SAR High Speed Analog-to-Digital Converter (HSADC) parameters.....	33		

# 1 Ratings

## 1.1 Thermal handling ratings

Symbol	Description	Min.	Max.	Unit	Notes
T <sub>STG</sub>	Storage temperature	-55	150	°C	1
T <sub>SDR</sub>	Solder temperature, lead-free	—	260	°C	2

1. Determined according to JEDEC Standard JESD22-A103, *High Temperature Storage Life*.
2. Determined according to IPC/JEDEC Standard J-STD-020, *Moisture/Reflow Sensitivity Classification for Nonhermetic Solid State Surface Mount Devices*.

## 1.2 Moisture handling ratings

Symbol	Description	Min.	Max.	Unit	Notes
MSL	Moisture sensitivity level	—	3	—	1

1. Determined according to IPC/JEDEC Standard J-STD-020, *Moisture/Reflow Sensitivity Classification for Nonhermetic Solid State Surface Mount Devices*.

## 1.3 ESD handling ratings

Symbol	Description	Min.	Max.	Unit	Notes
V <sub>HBM</sub>	Electrostatic discharge voltage, human-body model	-2000	+2000	V	1
V <sub>CDM</sub>	Electrostatic discharge voltage, charged-device model	-500	+500	V	2
I <sub>LAT</sub>	Latch-up current at ambient temperature of 105 °C	-100	+100	mA	3

1. Determined according to JEDEC Standard JESD22-A114, *Electrostatic Discharge (ESD) Sensitivity Testing Human Body Model (HBM)*.
2. Determined according to JEDEC Standard JESD22-C101, *Field-Induced Charged-Device Model Test Method for Electrostatic-Discharge-Withstand Thresholds of Microelectronic Components*.
3. Determined according to JEDEC Standard JESD78, *IC Latch-up Test*.

## 1.4 Voltage and current operating ratings

Symbol	Description	Min.	Max.	Unit
$V_{DD}$	Digital supply voltage	-0.3	3.6	V
$I_{DD}$	Digital supply current	—	300 <sup>1</sup>	mA
$V_{IO}$	Digital pin input voltage (except open drain pins)	-0.3	$V_{DD} + 0.3$ <sup>2</sup>	V
$I_D$	Instantaneous maximum current single pin limit (applies to all port pins)	-25	25	mA
$V_{DDA}$	Analog supply voltage	$V_{DD} - 0.3$	$V_{DD} + 0.3$	V

1. All  $V_{DD}/V_{SS}$  pins must be utilized for this value to be valid.
2. Maximum value of  $V_{IO}$  must be 3.8 V.

## 2 General

### 2.1 AC electrical characteristics

Unless otherwise specified, propagation delays are measured from the 50% to the 50% point, and rise and fall times are measured at the 20% and 80% points, as shown in the following figure.

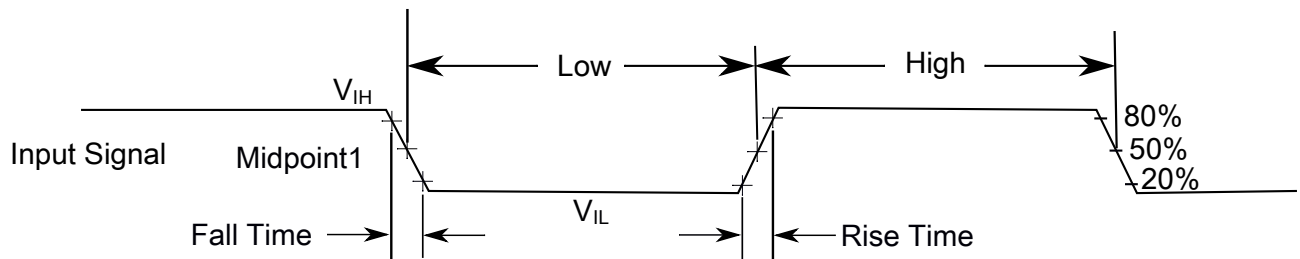

The midpoint is  $V_{IL} + (V_{IH} - V_{IL}) / 2$

**Figure 2. Input signal measurement reference**

All digital I/O switching characteristics, unless otherwise specified, assume:

1. output pins
  - have  $C_L=30\text{pF}$  loads,
  - are slew rate disabled, and
  - are normal drive strength

### 2.2 Nonswitching electrical specifications

## 2.2.1 Operating Requirements

This section includes information about recommended operating conditions.

### NOTE

Recommended  $V_{DD}$  ramp rate is between 1 ms and 200 ms.

**Table 1. Operating Requirements ( $V_{REFLx}=0V$ ,  $V_{SSA}=0V$ ,  $V_{SS}=0V$ )**

Symbol	Description	Notes <sup>1</sup>	Min	Max	Unit
$V_{DD}$	Digital supply voltage		1.71	3.6	V
$V_{DDA}$	Analog supply voltage		$V_{DD}$	3.6	V
$V_{REFHx}$	ADC Reference Voltage High		1.8	$V_{DDA}$	V
$\Delta V_{DD}$	Voltage difference $V_{DD}$ to $V_{DDA}$		-0.1	0.1	V
$\Delta V_{SS}$	Voltage difference $V_{SS}$ to $V_{SSA}$		-0.1	0.1	V
$F_{MCGOUT}$	Device Clock Frequency		0.04	100	MHz
$T$	<ul style="list-style-type: none"> <li>• using internal RC oscillator</li> <li>• using external clock source</li> </ul>		0	220	
$V_{IH}$	Input Voltage High (digital inputs)		$0.7 \times V_{DD}$	—	V
$V_{IL}$	Input Voltage Low (digital inputs)			$0.35 \times V_{DD}$	V
$T_A$	Ambient Operating Temperature		-40	105	°C

#### 1. Default Mode

- Pin Group 1: GPIO, TDI, TDO, TMS, TCK
- Pin Group 2: RESET
- Pin Group 3: ADC and Comparator Analog Inputs
- Pin Group 4: XTAL, EXTAL
- Pin Group 5: DAC analog output
- Pin Group 6: PTB0, PTB1, PTD4, PTD5, PTD6, PTD7, PTC3, and PTC4. have high output current capability

## 2.2.2 HVD, LVD, and POR operating requirements

**Table 2.  $V_{DD}$  supply HVD, LVD and POR operating requirements**

Symbol	Description	Min.	Typ.	Max.	Unit	Notes
$V_{POR}$	Falling $V_{DD}$ POR detect voltage	0.8	1.1	1.5	V	
$V_{LVDH}$	Falling low-voltage detect threshold — high range (LVDV=01)	2.48	2.56	2.64	V	
$V_{LVW1H}$	Low-voltage warning thresholds — high range					1
	• Level 1 falling (LVWV=00)	2.62	2.70	2.78	V	
$V_{LVW2H}$	• Level 2 falling (LVWV=01)	2.72	2.80	2.88	V	
$V_{LVW3H}$	• Level 3 falling (LVWV=10)	2.82	2.90	2.98	V	
$V_{LVW4H}$	• Level 4 falling (LVWV=11)	2.92	3.00	3.08	V	
$V_{HYSH}$	Low-voltage inhibit reset/recover hysteresis — high range	—	±80	—	mV	

Table continues on the next page...



**Table 2. V<sub>DD</sub> supply HVD, LVD and POR operating requirements (continued)**

Symbol	Description	Min.	Typ.	Max.	Unit	Notes
V <sub>LVDL</sub>	Falling low-voltage detect threshold — low range (LVDV=00)	1.54	1.60	1.66	V	
V <sub>HVDH</sub>	High Voltage Detect (High Trip Point)	—	3.7202	—	V	
V <sub>HVDL</sub>	High Voltage Detect (Low Trip Point)	—	3.4582	—	V	
V <sub>LVW1L</sub>	Low-voltage warning thresholds — low range <ul style="list-style-type: none"> <li>• Level 1 falling (LVWV=00)</li> <li>• Level 2 falling (LVWV=01)</li> <li>• Level 3 falling (LVWV=10)</li> <li>• Level 4 falling (LVWV=11)</li> </ul>	1.74	1.80	1.86	V	1
V <sub>LVW2L</sub>		1.84	1.90	1.96	V	
V <sub>LVW3L</sub>		1.94	2.00	2.06	V	
V <sub>LVW4L</sub>		2.04	2.10	2.16	V	
V <sub>HYSL</sub>	Low-voltage inhibit reset/recover hysteresis — low range	—	±60	—	mV	
V <sub>BG</sub>	Bandgap voltage reference	0.97	1.00	1.03	V	
t <sub>LPO</sub>	Internal low power oscillator period — factory trimmed	900	1000	1100	µs	

1. Rising thresholds are falling threshold + hysteresis voltage

## 2.2.3 PORT Voltage and current operating behaviors

**Table 3. Voltage and current operating behaviors**

Symbol	Description	Min.	Typ.	Max.	Unit	Notes
V <sub>OH</sub>	Output high voltage — Normal drive pad except RESET_B					
	2.7 V ≤ V <sub>DD</sub> ≤ 3.6 V, I <sub>OH</sub> = -10 mA	V <sub>DD</sub> - 0.5	—	—	V	1
	1.71 V ≤ V <sub>DD</sub> ≤ 2.7 V, I <sub>OH</sub> = -5 mA	V <sub>DD</sub> - 0.5	—	—	V	
V <sub>OH</sub>	Output high voltage — High drive pad except RESET_B					
	2.7 V ≤ V <sub>DD</sub> ≤ 3.6 V, I <sub>OH</sub> = -20 mA	V <sub>DD</sub> - 0.5	—	—	V	1
	1.71 V ≤ V <sub>DD</sub> ≤ 2.7 V, I <sub>OH</sub> = -10 mA	V <sub>DD</sub> - 0.5	—	—	V	
I <sub>OHT</sub>	Output high current total for all ports	—	—	100	mA	
V <sub>OL</sub>	Output low voltage — Normal drive pad except RESET_B					
	2.7 V ≤ V <sub>DD</sub> ≤ 3.6 V, I <sub>OL</sub> = 5 mA	—	—	0.5	V	1
	1.71 V ≤ V <sub>DD</sub> ≤ 2.7 V, I <sub>OL</sub> = 2.5 mA	—	—	0.5	V	
V <sub>OL</sub>	Output low voltage — High drive pad except RESET_B					
	2.7 V ≤ V <sub>DD</sub> ≤ 3.6 V, I <sub>OL</sub> = 20 mA	—	—	0.5	V	1
	1.71 V ≤ V <sub>DD</sub> ≤ 2.7 V, I <sub>OL</sub> = 10 mA	—	—	0.5	V	
V <sub>OL</sub>	Output low voltage — RESET_B					

Table continues on the next page...

**Table 3. Voltage and current operating behaviors (continued)**

Symbol	Description	Min.	Typ.	Max.	Unit	Notes
	$2.7\text{ V} \leq V_{DD} \leq 3.6\text{ V}$ , $I_{OL} = 3\text{ mA}$	—	—	0.5	V	
	$1.71\text{ V} \leq V_{DD} \leq 2.7\text{ V}$ , $I_{OL} = 1.5\text{ mA}$	—	—	0.5	V	
$I_{OLT}$	Output low current total for all ports	—	—	100	mA	
$I_{IN}$	Input leakage current (per pin) for full temperature range					
	All pins other than high drive port pins	—	0.002	0.5	$\mu\text{A}$	1, 2
	High drive port pins	—	0.004	0.5	$\mu\text{A}$	
$I_{ICIO}$	IO pin negative DC injection current – single pin. $V_{IN} < V_{SS} - 0.3\text{V}$	-3	—	—	mA	3
$I_{ICcont}$	Contiguous pin DC injection current – regional limit, includes sum of negative injection currents of 16 contiguous pins	-25	—	—	mA	
$V_{ODPU}$	Open drain pullup voltage level	$V_{DD}$	—	$V_{DD}$	mA	4
$R_{PU}$	Internal pullup resistors	20	—	50	k $\Omega$	5
$R_{PD}$	Internal pulldown resistors	20	—	50	k $\Omega$	6

1. PTB0, PTB1, PTC3, PTC4, PTD4, PTD5, PTD6, and PTD7 I/O have both high drive and normal drive capability selected by the associated PTx\_PCRn[DSE] control bit. All other GPIOs are normal drive only.
2. Measured at  $V_{DD}=3.6\text{V}$
3. All I/O pins are internally clamped to  $V_{SS}$  through an ESD protection diode. There is no diode connection to  $V_{DD}$ . If  $V_{IN}$  is greater than  $V_{IO\_MIN}$  ( $= V_{SS}-0.3\text{ V}$ ), then there is no need to provide current limiting resistors at the pads. If this limit cannot be observed then a current limiting resistor is required. The negative DC injection current limiting resistor is calculated as  $R = (V_{IO\_MIN} - V_{IN})/|I_{ICIO}|$ .
4. Open drain outputs must be pulled to  $V_{DD}$ .
5. Measured at  $V_{DD}$  supply voltage =  $V_{DD}$  min and  $V_{input} = V_{SS}$
6. Measured at  $V_{DD}$  supply voltage =  $V_{DD}$  min and  $V_{input} = V_{DD}$

## 2.2.4 Power mode transition operating behaviors

All specifications except  $t_{POR}$  and  $V_{LLSx} \rightarrow \text{RUN}$  recovery times in the following table assume this clock configuration:

- CPU and system clocks = 100 MHz
- Bus and flash clock = 25 MHz
- FEI clock mode

**Table 4. Power mode transition operating behaviors**

Symbol	Description	Min.	Typ.	Max.	Unit	Notes
$t_{POR}$	After a POR event, amount of time from the point $V_{DD}$ reaches 1.71 V to execution of the	—	—	300	$\mu\text{s}$	

*Table continues on the next page...*

**Table 4. Power mode transition operating behaviors (continued)**

Symbol	Description	Min.	Typ.	Max.	Unit	Notes
	first instruction across the operating temperature range of the chip.					
	• VLLS0 → RUN	—	—	149	μs	
	• VLLS1 → RUN	—	—	149	μs	
	• VLLS3 → RUN	—	—	79	μs	
	• VLPS → RUN	—	—	5.5	μs	
	• STOP → RUN	—	—	5.5	μs	

## 2.2.5 Power consumption operating behaviors

**Table 5. Power consumption operating behaviors**

Symbol	Description	Min.	Typ.	Max.	Unit	Notes
I <sub>DDA</sub>	Analog supply current	—	5	8	mA	HSADC0 and HSADC1 with 66.6 MHz clock, ADC0 with 25 MHz clock.
I <sub>DD_RUN</sub>	Run mode current — all peripheral clocks disabled, code executing from flash, excludes ADC IDDA • @ 1.8V • @ 3.0V	—	18	—	mA	Core frequency of 25 MHz
		—	18	—	mA	
I <sub>DD_RUN</sub>	Run mode current — all peripheral clocks disabled, code executing from flash, excludes ADC IDDA • @ 1.8V • @ 3.0V	—	55	—	mA	Core frequency of 50 MHz
		—	55	—	mA	
I <sub>DD_RUN</sub>	Run mode current — all peripheral clocks disabled, code executing from flash, excludes ADC IDDA • @ 3.0V	—	27	—	mA	Core frequency of 160 MHz.

Table continues on the next page...

**Table 5. Power consumption operating behaviors (continued)**

Symbol	Description	Min.	Typ.	Max.	Unit	Notes
	<ul style="list-style-type: none"> <li>• @25°C</li> <li>• @105°C</li> </ul>	—	57	—	mA	
I <sub>DD_HSRUN</sub>	Run mode current — all peripheral clocks disabled, code executing from flash, excludes ADC IDDA <ul style="list-style-type: none"> <li>• @ 3.0V</li> <li>• @25°C</li> <li>• @105°C</li> </ul>	—	45	—	mA	Core frequency of 220 MHz.
		—	80	—	mA	
I <sub>DD_HSRUN</sub>	Run mode current — all peripheral clocks enabled, code executing from flash,excludes ADC IDDA <ul style="list-style-type: none"> <li>• @ 3.0V</li> <li>• @ 25°C</li> <li>• @ 105°C</li> </ul>	—	69	—	mA	Core frequency of 220 MHz. Nanoedge module at 110 MHz.
		—	105	—	mA	
I <sub>DD_WAIT</sub>	Wait mode high frequency current at 3.0 V — all peripheral clocks disabled	—	18	—	mA	160 MHz PEE mode, Fast Peripheral clock = 80 MHz, Flexbus clock = 80 MHz, Bus/Flash clock = 20 MHz
I <sub>DD_VLPR</sub>	Very-low-power run mode current at 3.0 V — all peripheral clocks disabled	—	1.0	—	mA	CPU frequency 4 MHz
I <sub>DD_VLPR</sub>	Very-low-power run mode current at 3.0 V — all peripheral clocks enabled	—	1.4	—	mA	CPU frequency 4 MHz
I <sub>DD_VLPW</sub>	Very-low-power wait mode current at 3.0 V — all peripheral clocks disabled	—	0.71	—	mA	4 MHz System/ Core clock, Fast peripheral clock, and Flexbus clock. 1 MHz bus/ flash clock. All peripheral clocks disabled. Temp = 25°C.
I <sub>DD_STOP</sub>	Stop mode current at 3.0 V <ul style="list-style-type: none"> <li>• @ -40 to 25°C</li> <li>• @ 105°C</li> </ul>	—	0.6	—	mA	
		—	24	—	mA	
I <sub>DD_VLPS</sub>	Very-low-power stop mode current at 3.0 V	—	0.23	—	mA	
		—	9	—	mA	

Table continues on the next page...

**Table 5. Power consumption operating behaviors (continued)**

Symbol	Description	Min.	Typ.	Max.	Unit	Notes
	<ul style="list-style-type: none"> <li>• @ -40 to 25°C</li> <li>• @ 105°C</li> </ul>					
$I_{DD\_VLLS3}$	Very low-leakage stop mode 3 current at 3.0 V <ul style="list-style-type: none"> <li>• @ -40 to 25°C</li> <li>• @ 70°C</li> <li>• @ 105°C</li> </ul>	—	10.2	—	μA	
		—	50.4	—	μA	
		—	184.5	—	μA	
$I_{DD\_VLLS2}$	Very low-leakage stop mode 2 current at 3.0 V <ul style="list-style-type: none"> <li>• @ -40 to 25°C</li> <li>• @ 70°C</li> <li>• @ 105°C</li> </ul>	—	6.6	—	μA	
		—	18.3	—	μA	
		—	66.0	—	μA	
$I_{DD\_VLLS1}$	Very low-leakage stop mode 1 current at 3.0 V <ul style="list-style-type: none"> <li>• @ -40 to 25°C</li> <li>• @ 70°C</li> <li>• @ 105°C</li> </ul>	—	0.69	—	μA	
		—	3.7	—	μA	
		—	19.3	—	μA	
$I_{DD\_VLLS0B}$	Very low-leakage stop mode 0 current at 3.0 V with POR detect circuit enabled <ul style="list-style-type: none"> <li>• @ -40 to 25°C</li> <li>• @ 70°C</li> <li>• @ 105°C</li> </ul>	—	0.4	—	μA	
		—	3.4	—	μA	
		—	18.6	—	μA	
$I_{DD\_VLLS0A}$	Very low-leakage stop mode 0 current at 3.0 V with POR detect circuit disabled <ul style="list-style-type: none"> <li>• @ -40 to 25°C</li> <li>• @ 70°C</li> <li>• @ 105°C</li> </ul>	—	0.127	—	μA	
		—	3.0	—	μA	
		—	18.2	—	μA	

**NOTE**

The values in the table below are preliminary data and are subject to change.

**Table 6. Low power mode peripheral adders — typical value**

Symbol	Description	Temperature (°C)						Unit
		-40	25	50	70	85	105	
I <sub>IREFSTEN4MHZ</sub>	4 MHz internal reference clock (IRC) adder. Measured by entering STOP or VLPS mode with 4 MHz IRC enabled.	56	56	56	56	56	56	μA
I <sub>IREFSTEN32KHZ</sub>	32 kHz internal reference clock (IRC) adder. Measured by entering STOP mode with the 32 kHz IRC enabled.	52	52	52	52	52	52	μA
I <sub>EREFSTEN4MHZ</sub>	External 4 MHz crystal clock adder. Measured by entering STOP or VLPS mode with the crystal enabled.	206	228	237	245	251	258	μA
I <sub>EREFSTEN32KHZ</sub>	External 32 kHz crystal clock adder by means of the OSC0_CR[EREFSTEN and EREFSTEN] bits. Measured by entering all modes with the crystal enabled.							nA
	VLLS1							
	VLLS3	440	490	540	560	570	580	
	LLS	440	490	540	560	570	580	
	VLPS	490	490	540	560	570	680	
	STOP	510	560	560	560	610	680	
I <sub>CMP</sub>	CMP peripheral adder measured by placing the device in VLLS1 mode with CMP enabled using the 6-bit DAC and a single external input for compare. Includes 6-bit DAC power consumption.	22	22	22	22	22	22	μA
I <sub>UART</sub>	UART peripheral adder measured by placing the device in STOP or VLPS mode with selected clock source waiting for RX data at 115200 baud rate. Includes selected clock source power consumption.							μA
	MCGIRCLK (4 MHz internal reference clock)	66	66	66	66	66	66	
	OSCCERCLK (4 MHz external crystal)	214	234	246	254	260	268	
I <sub>BG</sub>	Bandgap adder when BGEN bit is set and device is placed in VLPx, LLS, or VLLSx mode.	45	45	45	45	45	45	μA

## 2.2.6 EMC radiated emissions operating behaviors

**Table 7. EMC radiated emissions operating behaviors**

Symbol	Conditions	Clocks	Frequency band (MHz)	Typ.	Unit	Notes
V <sub>EME</sub>	Device configuration, test conditions and EM testing per standard IEC 61967-2. <ul style="list-style-type: none"> <li>Supply voltage VDD = 3.3 V</li> <li>Temperature = 25 °C</li> </ul>	<ul style="list-style-type: none"> <li>f<sub>OSC</sub> = 20 MHz (crystal)</li> <li>f<sub>SYS</sub> = 150 MHz</li> </ul>	0.15–50	14	dBμV	1
			50–150	25	dBμV	
			150–500	23	dBμV	
			500–1000	16	dBμV	
			0.15–1000	K	—	2

1. Determined according to IEC Standard 61967-1, *Integrated Circuits - Measurement of Electromagnetic Emissions, 150 kHz to 1 GHz Part 1: General Conditions and Definitions* and IEC Standard 61967-2, *Integrated Circuits - Measurement of Electromagnetic Emissions, 150 kHz to 1 GHz Part 2: Measurement of Radiated Emissions—TEM Cell and Wideband TEM Cell Method*. Measurements were made while the microcontroller was running basic application code. The reported emission level is the value of the maximum measured emission, rounded up to the next whole number, from among the measured orientations in each frequency range.
2. Specified according to Annex D of IEC Standard 61967-2, *Measurement of Radiated Emissions—TEM Cell and Wideband TEM Cell Method*

## 2.2.7 Designing with radiated emissions in mind

To find application notes that provide guidance on designing your system to minimize interference from radiated emissions:

1. Go to [www.freescale.com](http://www.freescale.com).
2. Perform a keyword search for “EMC design.”

## 2.2.8 Capacitance attributes

**Table 8. Capacitance attributes**

Symbol	Description	Min.	Max.	Unit
C <sub>IN_A</sub>	Input capacitance: analog pins	—	7	pF
C <sub>IN_D</sub>	Input capacitance: digital pins	—	7	pF

## 2.3 Switching specifications

## 2.3.1 Typical device clock specifications

**Table 9. Device clock specifications**

Symbol	Description	Min.	Max.	Unit	Notes
High Speed run mode					
$f_{sys}$	System (CPU) clock	—	220	MHz	
Normal run mode (and High Speed run mode unless otherwise specified above)					
$f_{sys}$	System (CPU) clock	—	160	MHz	
$f_{FastPeripheral}$	Fast Peripheral Clock	—	110	MHz	1
FB_CLK	FlexBus clock	—	55	MHz	
$f_{Bus\_Flash}$	Bus / Flash clock	—	27.5	MHz	
$f_{LPTMR}$	LPTMR clock	—	24	MHz	
VLPR mode					
$f_{sys}$	System (CPU) clock	—	4	MHz	
$f_{FastPeripheral}$	Fast Peripheral Clock	—	4	MHz	
FB_CLK	FlexBus clock	—	4	MHz	
$f_{Bus\_Flash}$	Bus / Flash Clock	—	500	kHz	
$f_{ERCLK}$	External reference clock	—	16	MHz	
$f_{LPTMR}$	LPTMR clock	—	24	MHz	2

1. When using this clock to supply the nano-edge module, this clock must be 1/2 of the system clock.
2. The LPTMR can be clocked at this speed in VLPR or VLPS only when the source is a clock input connected to the EXTAL pin with the OSC configured for bypass (external clock) operation.

## 2.3.2 General switching specifications

These general purpose specifications apply to all signals configured for GPIO, UART, FlexCAN, and I<sup>2</sup>C signals.

**Table 10. General switching specifications**

Description	Min.	Max.	Unit	Notes
GPIO pin interrupt pulse width (digital glitch filter disabled) — Synchronous path	1.5	—	Bus clock cycles	1
GPIO pin interrupt pulse width (digital glitch filter enabled, analog filter disabled) — Asynchronous path	80	—	ns	2
GPIO pin interrupt pulse width (digital glitch filter disabled, analog filter disabled) — Asynchronous path	50	—	ns	2
External RESET and NMI pin interrupt pulse width — Asynchronous path	100	—	ns	2
GPIO pin interrupt pulse width — Asynchronous path	10	—	ns	2
Normal drive fast pins • $2.7 \leq VDD \leq 3.6$ V				3, 4

Table continues on the next page...



**Table 10. General switching specifications (continued)**

Description	Min.	Max.	Unit	Notes
<ul style="list-style-type: none"> <li>Fast slew rate</li> <li>Slow slew rate</li> <li>1.71 ≤ VDD &lt; 2.7 V                             <ul style="list-style-type: none"> <li>Fast slew rate</li> <li>Slow slew rate</li> </ul> </li> </ul>	—	0.7	ns	
<ul style="list-style-type: none"> <li>Fast slew rate</li> <li>Slow slew rate</li> <li>1.71 ≤ VDD &lt; 2.7 V                             <ul style="list-style-type: none"> <li>Fast slew rate</li> <li>Slow slew rate</li> </ul> </li> </ul>	—	16	ns	
<ul style="list-style-type: none"> <li>Fast slew rate</li> <li>Slow slew rate</li> <li>1.71 ≤ VDD &lt; 2.7 V                             <ul style="list-style-type: none"> <li>Fast slew rate</li> <li>Slow slew rate</li> </ul> </li> </ul>	—	2.15		
<ul style="list-style-type: none"> <li>Fast slew rate</li> <li>Slow slew rate</li> <li>1.71 ≤ VDD &lt; 2.7 V                             <ul style="list-style-type: none"> <li>Fast slew rate</li> <li>Slow slew rate</li> </ul> </li> </ul>	—	16		
High drive fast pins (normal/low drive enabled) <ul style="list-style-type: none"> <li>2.7 ≤ VDD ≤ 3.6 V               <ul style="list-style-type: none"> <li>Fast slew rate</li> <li>Slow slew rate</li> </ul> </li> <li>1.71 ≤ VDD &lt; 2.7 V               <ul style="list-style-type: none"> <li>Fast slew rate</li> <li>Slow slew rate</li> </ul> </li> </ul>	—	0.7	ns	3, 5
	—	15.65	ns	
		2.35		
		35.3		
High drive fast pins (high drive enabled) <ul style="list-style-type: none"> <li>2.7 ≤ VDD ≤ 3.6 V               <ul style="list-style-type: none"> <li>Fast slew rate</li> <li>Slow slew rate</li> </ul> </li> <li>1.71 ≤ VDD &lt; 2.7 V               <ul style="list-style-type: none"> <li>Fast slew rate</li> <li>Slow slew rate</li> </ul> </li> </ul>	—	3	ns	
	—	16.5	ns	
		6.5		
		36.3		

- The synchronous and asynchronous timing must be met.
- This is the shortest pulse that is guaranteed to be recognized.
- For high drive pins with high drive enabled, load is 75pF; other pins load (normal/low drive) is 25pF. Fast slew rate is enabled by clearing PORTx\_PCRn[SRE].
- Normal drive fast pins: All other GPIO pins that are not high drive fast pins.
- High drive fast pins: PTB0, PTB1, PTC3, PTC4, PTD4, PTD5, PTD6, and PTD7. High drive capability is enabled by setting PORTx\_PCRn[DSE]

## 2.4 Thermal specifications

### 2.4.1 Thermal operating requirements

**Table 11. Thermal operating requirements**

Symbol	Description	Min.	Max.	Unit	Notes
T <sub>J</sub>	Die junction temperature	-40	125	°C	
T <sub>A</sub>	Ambient temperature	-40	105	°C	1

- Maximum T<sub>A</sub> can be exceeded only if the user ensures that T<sub>J</sub> does not exceed maximum T<sub>J</sub>. The simplest method to determine T<sub>J</sub> is:

$$T_J = T_A + R_{\theta JA} \times \text{chip power dissipation}$$

## 2.4.2 Thermal attributes

Table 12. Thermal attributes

Board type	Symbol	Description	144 MAPBG A <sup>1</sup>	144 LQFP	100 LQFP	Unit	Notes
Single-layer (1S)	R <sub>θJA</sub>	Thermal resistance, junction to ambient (natural convection)	—	51	51	°C/W	2
Four-layer (2s2p)	R <sub>θJA</sub>	Thermal resistance, junction to ambient (natural convection)	—	42	38	°C/W	
Single-layer (1S)	R <sub>θJMA</sub>	Thermal resistance, junction to ambient (200 ft./min. air speed)	—	42	41	°C/W	
Four-layer (2s2p)	R <sub>θJMA</sub>	Thermal resistance, junction to ambient (200 ft./min. air speed)	—	36	32	°C/W	
—	R <sub>θJB</sub>	Thermal resistance, junction to board	—	30	23	°C/W	3
—	R <sub>θJC</sub>	Thermal resistance, junction to case	—	11	10	°C/W	4
—	Ψ <sub>JT</sub>	Thermal characterization parameter, junction to package top outside center (natural convection)	—	2	2	°C/W	5

1. Package Your Way
2. Determined according to JEDEC Standard JESD51-2, *Integrated Circuits Thermal Test Method Environmental Conditions—Natural Convection (Still Air)*, or EIA/JEDEC Standard JESD51-6, *Integrated Circuit Thermal Test Method Environmental Conditions—Forced Convection (Moving Air)*.
3. Determined according to JEDEC Standard JESD51-8, *Integrated Circuit Thermal Test Method Environmental Conditions—Junction-to-Board*.
4. Determined according to Method 1012.1 of MIL-STD 883, *Test Method Standard, Microcircuits*, with the cold plate temperature used for the case temperature. The value includes the thermal resistance of the interface material between the top of the package and the cold plate.
5. Determined according to JEDEC Standard JESD51-2, *Integrated Circuits Thermal Test Method Environmental Conditions—Natural Convection (Still Air)*.

## 3 Peripheral operating requirements and behaviors

### 3.1 Core modules

### 3.1.1 SWD Electricals

**Table 13. SWD full voltage range electricals**

Symbol	Description	Min.	Max.	Unit
	Operating voltage	1.71	3.6	V
J1	SWD_CLK frequency of operation <ul style="list-style-type: none"> <li>Serial wire debug</li> </ul>	0	25	MHz
J2	SWD_CLK cycle period	1/J1	—	ns
J3	SWD_CLK clock pulse width <ul style="list-style-type: none"> <li>Serial wire debug</li> </ul>	20	—	ns
J4	SWD_CLK rise and fall times	—	3	ns
J9	SWD_DIO input data setup time to SWD_CLK rise	10	—	ns
J10	SWD_DIO input data hold time after SWD_CLK rise	0	—	ns
J11	SWD_CLK high to SWD_DIO data valid	—	32	ns
J12	SWD_CLK high to SWD_DIO high-Z	5	—	ns

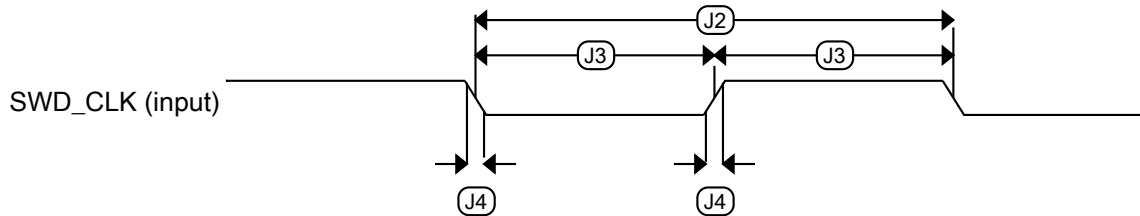

**Figure 3. Serial wire clock input timing**

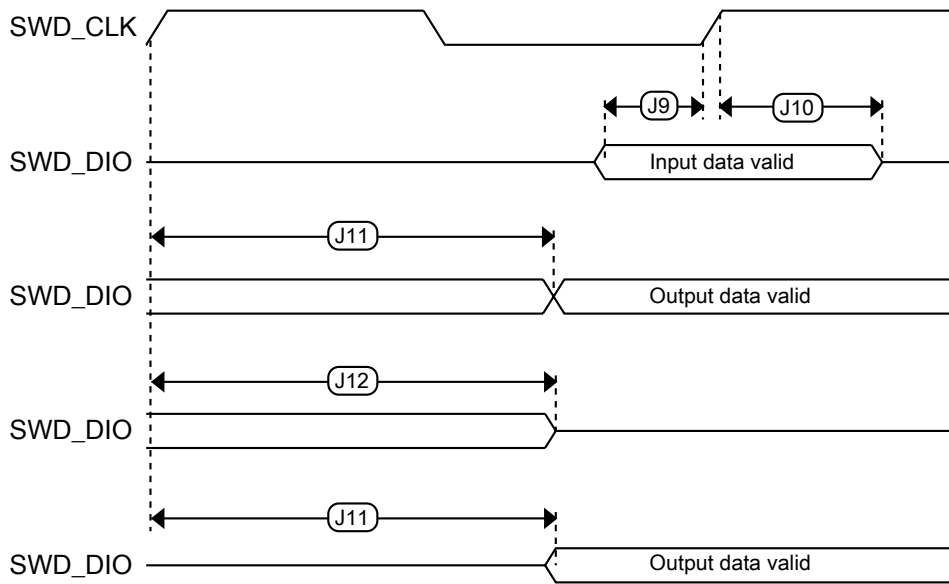
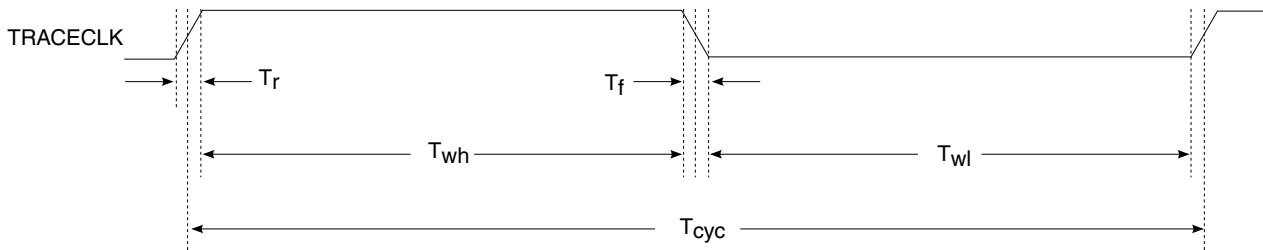
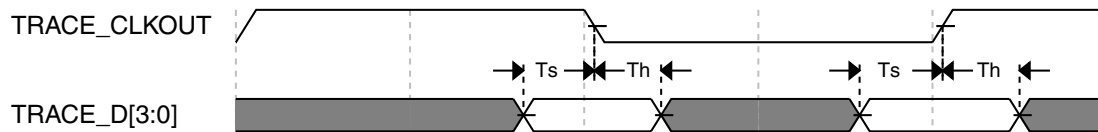

Figure 4. Serial wire data timing

### 3.1.2 Debug trace timing specifications

Table 14. Debug trace operating behaviors

Symbol	Description	Min.	Max.	Unit
$T_{cyc}$	Clock period	Frequency dependent		MHz
$T_{wl}$	Low pulse width	2	—	ns
$T_{wh}$	High pulse width	2	—	ns
$T_r$	Clock and data rise time	—	3	ns
$T_f$	Clock and data fall time	—	3	ns
$T_s$	Data setup	3	1.5	ns
$T_h$	Data hold	2	1.0	ns

**Figure 5. TRACE\_CLKOUT specifications**

**Figure 6. Trace data specifications**

### 3.1.3 JTAG electricals

**Table 15. JTAG limited voltage range electricals**

Symbol	Description	Min.	Max.	Unit
	Operating voltage	2.7	3.6	V
J1	TCLK frequency of operation <ul style="list-style-type: none"> <li>• Boundary Scan</li> <li>• JTAG and CJTAG</li> <li>• Serial Wire Debug</li> </ul>	0	10	MHz
J2	TCLK cycle period	1/J1	—	ns
J3	TCLK clock pulse width <ul style="list-style-type: none"> <li>• Boundary Scan</li> <li>• JTAG and CJTAG</li> <li>• Serial Wire Debug</li> </ul>	50	—	ns
J4	TCLK rise and fall times	—	3	ns
J5	Boundary scan input data setup time to TCLK rise	20	—	ns
J6	Boundary scan input data hold time after TCLK rise	2.0	—	ns
J7	TCLK low to boundary scan output data valid	—	28	ns
J8	TCLK low to boundary scan output high-Z	—	25	ns
J9	TMS, TDI input data setup time to TCLK rise	8	—	ns
J10	TMS, TDI input data hold time after TCLK rise	1	—	ns

Table continues on the next page...

**Table 15. JTAG limited voltage range electricals (continued)**

Symbol	Description	Min.	Max.	Unit
J11	TCLK low to TDO data valid	—	19	ns
J12	TCLK low to TDO high-Z	—	17	ns
J13	$\overline{\text{TRST}}$ assert time	100	—	ns
J14	$\overline{\text{TRST}}$ setup time (negation) to TCLK high	8	—	ns

**Table 16. JTAG full voltage range electricals**

Symbol	Description	Min.	Max.	Unit
	Operating voltage	1.71	3.6	V
J1	TCLK frequency of operation <ul style="list-style-type: none"> <li>• Boundary Scan</li> <li>• JTAG and CJTAG</li> <li>• Serial Wire Debug</li> </ul>	0 0 0	10 20 40	MHz
J2	TCLK cycle period	1/J1	—	ns
J3	TCLK clock pulse width <ul style="list-style-type: none"> <li>• Boundary Scan</li> <li>• JTAG and CJTAG</li> <li>• Serial Wire Debug</li> </ul>	50 25 12.5	— — —	ns ns ns
J4	TCLK rise and fall times	—	3	ns
J5	Boundary scan input data setup time to TCLK rise	20	—	ns
J6	Boundary scan input data hold time after TCLK rise	2.0	—	ns
J7	TCLK low to boundary scan output data valid	—	30.6	ns
J8	TCLK low to boundary scan output high-Z	—	25	ns
J9	TMS, TDI input data setup time to TCLK rise	8	—	ns
J10	TMS, TDI input data hold time after TCLK rise	1.0	—	ns
J11	TCLK low to TDO data valid	—	19.0	ns
J12	TCLK low to TDO high-Z	—	17.0	ns
J13	$\overline{\text{TRST}}$ assert time	100	—	ns
J14	$\overline{\text{TRST}}$ setup time (negation) to TCLK high	8	—	ns

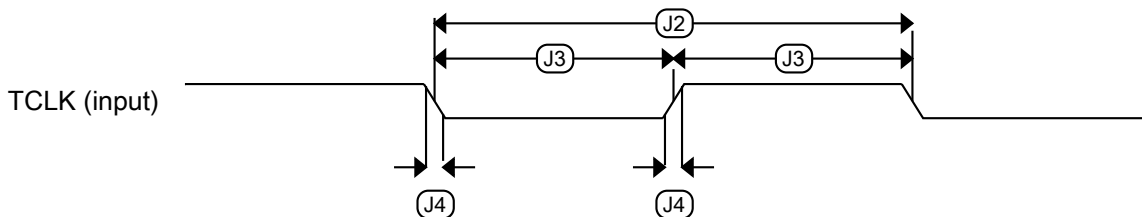

**Figure 7. Test clock input timing**

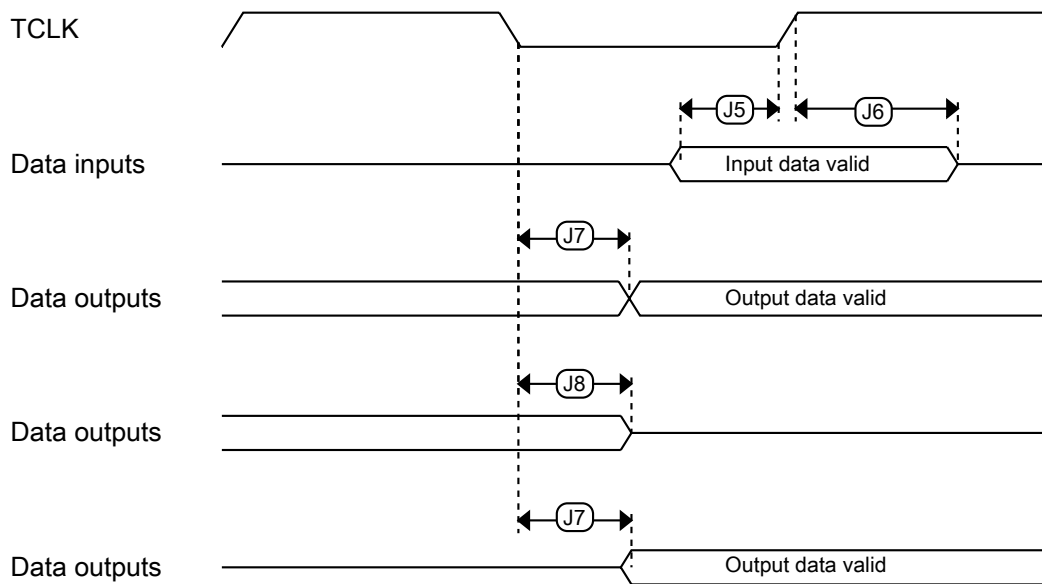

Figure 8. Boundary scan (JTAG) timing

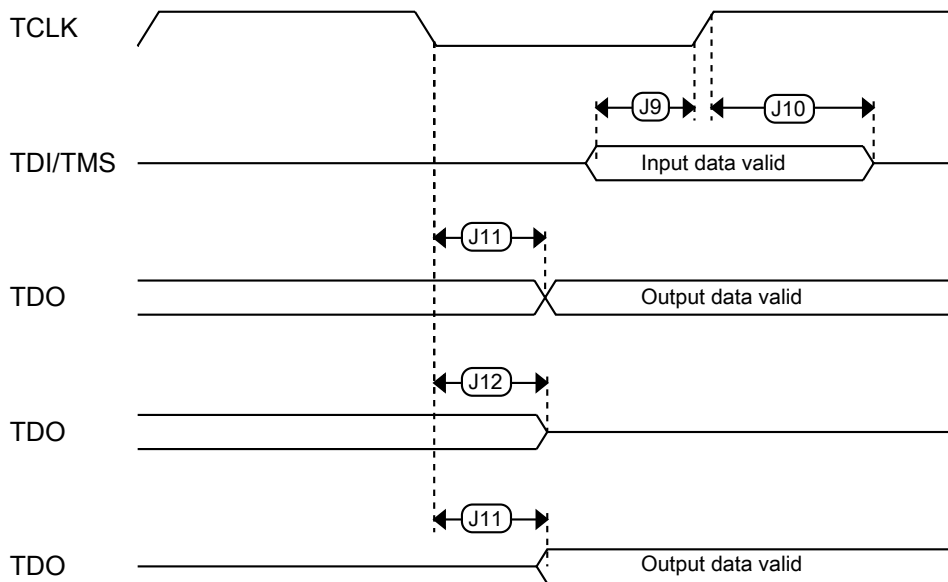

Figure 9. Test Access Port timing

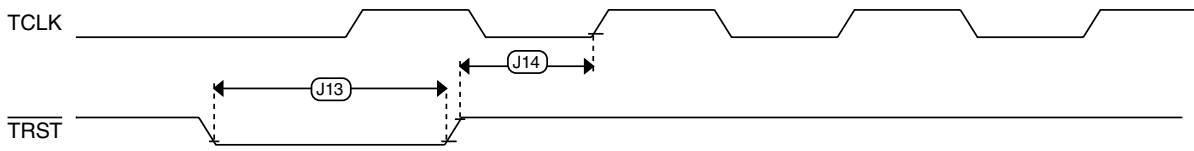

Figure 10.  $\overline{\text{TRST}}$  timing

### 3.2 System modules

There are no specifications necessary for the device's system modules.

### 3.3 Clock modules

#### 3.3.1 MCG specifications

Table 17. MCG specifications

Symbol	Description	Min.	Typ.	Max.	Unit	Notes
$f_{\text{ints\_ft}}$	Internal reference frequency (slow clock) — factory trimmed at nominal VDD and 25 °C	—	32.768	—	kHz	
$f_{\text{ints\_t}}$	Internal reference frequency (slow clock) — user trimmed	31.25	—	39.0625	kHz	
$\Delta f_{\text{dco\_res\_t}}$	Resolution of trimmed average DCO output frequency at fixed voltage and temperature — using SCTRIM and SCFTRIM	—	$\pm 0.3$	$\pm 0.6$	$\%f_{\text{dco}}$	1
$\Delta f_{\text{dco\_res\_t}}$	Resolution of trimmed average DCO output frequency at fixed voltage and temperature — using SCTRIM only	—	$\pm 0.2$	$\pm 0.5$	$\%f_{\text{dco}}$	1
$\Delta f_{\text{dco\_t}}$	Total deviation of trimmed average DCO output frequency over voltage and temperature	—	$\pm 0.5$	$\pm 2$	$\%f_{\text{dco}}$	1,
$\Delta f_{\text{dco\_t}}$	Total deviation of trimmed average DCO output frequency over fixed voltage and temperature range of 0–70°C	—	—	$\pm 1$	$\%f_{\text{dco}}$	1
$f_{\text{intf\_ft}}$	Internal reference frequency (fast clock) — factory trimmed at nominal VDD and 25°C	—	4	—	MHz	
$f_{\text{intf\_t}}$	Internal reference frequency (fast clock) — user trimmed at nominal VDD and 25 °C	3	—	5	MHz	
$f_{\text{loc\_low}}$	Loss of external clock minimum frequency — RANGE = 00	$(3/5) \times f_{\text{ints\_t}}$	—	—	kHz	

Table continues on the next page...



**Table 17. MCG specifications (continued)**

Symbol	Description	Min.	Typ.	Max.	Unit	Notes	
$f_{loc\_high}$	Loss of external clock minimum frequency — RANGE = 01, 10, or 11	$(16/5) \times f_{ints\_t}$	—	—	kHz		
FLL							
$f_{fill\_ref}$	FLL reference frequency range	31.25	—	39.0625	kHz		
$f_{dco}$	DCO output frequency range	Low range (DRS=00) $640 \times f_{fill\_ref}$	20	20.97	25	MHz	2, 3
		Mid range (DRS=01) $1280 \times f_{fill\_ref}$	40	41.94	50	MHz	
		Mid-high range (DRS=10) $1920 \times f_{fill\_ref}$	60	62.91	75	MHz	
		High range (DRS=11) $2560 \times f_{fill\_ref}$	80	83.89	100	MHz	
$f_{dco\_t\_DMX3\_2}$	DCO output frequency	Low range (DRS=00) $732 \times f_{fill\_ref}$	—	23.99	—	MHz	4, 5
		Mid range (DRS=01) $1464 \times f_{fill\_ref}$	—	47.97	—	MHz	
		Mid-high range (DRS=10) $2197 \times f_{fill\_ref}$	—	71.99	—	MHz	
		High range (DRS=11) $2929 \times f_{fill\_ref}$	—	95.98	—	MHz	
$J_{cyc\_fll}$	FLL period jitter • $f_{DCO} = 48$ MHz • $f_{DCO} = 98$ MHz	— —	180 150	—	ps		
$t_{fill\_acquire}$	FLL target frequency acquisition time	—	—	1	ms	6	
PLL							
$f_{pll\_ref}$	PLL reference frequency range	8	—	16	MHz		
$f_{vcoclk\_2x}$	VCO output frequency	220	—	440	MHz		
$f_{vcoclk}$	PLL output frequency	110	—	220	MHz		
$f_{vcoclk\_90}$	PLL quadrature output frequency	110	—	220	MHz		
$I_{pll}$	PLL operating current • VCO @ 176 MHz ( $f_{osc\_hi\_1} = 32$ MHz, $f_{pll\_ref} = 8$ MHz, VDIV multiplier = 22)	—	2.8	—	mA	7	
$I_{pll}$	PLL operating current • VCO @ 360 MHz ( $f_{osc\_hi\_1} = 32$ MHz, $f_{pll\_ref} = 8$ MHz, VDIV multiplier = 45)	—	4.7	—	mA	7	
$J_{cyc\_pll}$	PLL period jitter (RMS) • $f_{vco} = 48$ MHz • $f_{vco} = 120$ MHz	—	120	—	ps	8	
		—	75	—	ps		
$J_{acc\_pll}$	PLL accumulated jitter over 1 $\mu$ s (RMS)					8	

Table continues on the next page...

**Table 17. MCG specifications (continued)**

Symbol	Description	Min.	Typ.	Max.	Unit	Notes
	<ul style="list-style-type: none"> <li><math>f_{VCO} = 48 \text{ MHz}</math></li> <li><math>f_{VCO} = 120 \text{ MHz}</math></li> </ul>	—	1350	—	ps	
		—	600	—	ps	
$D_{unl}$	Lock exit frequency tolerance	$\pm 4.47$	—	$\pm 5.97$	%	
$t_{pll\_lock}$	Lock detector detection time	—	—	$150 \times 10^{-6} + 1075(1/f_{pll\_ref})$	s	9

1. This parameter is measured with the internal reference (slow clock) being used as a reference to the FLL (FEI clock mode).
2. These typical values listed are with the slow internal reference clock (FEI) using factory trim and DMX32=0.
3. The resulting system clock frequencies should not exceed their maximum specified values. The DCO frequency deviation ( $\Delta f_{dco\_t}$ ) over voltage and temperature should be considered.
4. These typical values listed are with the slow internal reference clock (FEI) using factory trim and DMX32=1.
5. The resulting clock frequency must not exceed the maximum specified clock frequency of the device.
6. This specification applies to any time the FLL reference source or reference divider is changed, trim value is changed, DMX32 bit is changed, DRS bits are changed, or changing from FLL disabled (BLPE, BLPI) to FLL enabled (FEI, FEE, FBE, FBI). If a crystal/resonator is being used as the reference, this specification assumes it is already running.
7. Excludes any oscillator currents that are also consuming power while PLL is in operation.
8. This specification was obtained using a Freescale developed PCB. PLL jitter is dependent on the noise characteristics of each PCB and results will vary.
9. This specification applies to any time the PLL VCO divider or reference divider is changed, or changing from PLL disabled (BLPE, BLPI) to PLL enabled (PBE, PEE). If a crystal/resonator is being used as the reference, this specification assumes it is already running.

### 3.3.2 Oscillator electrical specifications

#### 3.3.2.1 Oscillator DC electrical specifications

**Table 18. Oscillator DC electrical specifications**

Symbol	Description	Min.	Typ.	Max.	Unit	Notes
$V_{DD}$	Supply voltage	1.71	—	3.6	V	
$I_{DDOSC}$	Supply current — low-power mode (HGO=0) <ul style="list-style-type: none"> <li>32 kHz</li> <li>4 MHz</li> <li>8 MHz</li> <li>16 MHz</li> <li>24 MHz</li> <li>32 MHz</li> </ul>	—	500	—	nA	1
		—	200	—	$\mu\text{A}$	
		—	300	—	$\mu\text{A}$	
		—	950	—	$\mu\text{A}$	
		—	1.2	—	mA	
		—	1.5	—	mA	
$I_{DDOSC}$	Supply current — high gain mode (HGO=1) <ul style="list-style-type: none"> <li>4 MHz</li> </ul>	—	400	—	$\mu\text{A}$	1

Table continues on the next page...

**Table 18. Oscillator DC electrical specifications (continued)**

Symbol	Description	Min.	Typ.	Max.	Unit	Notes
	<ul style="list-style-type: none"> <li>• 8 MHz</li> <li>• 16 MHz</li> <li>• 24 MHz</li> <li>• 32 MHz</li> </ul>	—	500	—	μA	
		—	2.5	—	mA	
		—	3	—	mA	
		—	4	—	mA	
$C_x$	EXTAL load capacitance	—	—	—		2, 3
$C_y$	XTAL load capacitance	—	—	—		2, 3
$R_F$	Feedback resistor — low-frequency, low-power mode (HGO=0)	—	—	—	MΩ	2, 4
	Feedback resistor — low-frequency, high-gain mode (HGO=1)	—	10	—	MΩ	
	Feedback resistor — high-frequency, low-power mode (HGO=0)	—	—	—	MΩ	
	Feedback resistor — high-frequency, high-gain mode (HGO=1)	—	1	—	MΩ	
$R_S$	Series resistor — low-frequency, low-power mode (HGO=0)	—	—	—	kΩ	
	Series resistor — low-frequency, high-gain mode (HGO=1)	—	200	—	kΩ	
	Series resistor — high-frequency, low-power mode (HGO=0)	—	—	—	kΩ	
	Series resistor — high-frequency, high-gain mode (HGO=1)	—	0	—	kΩ	
$V_{pp}^5$	Peak-to-peak amplitude of oscillation (oscillator mode) — low-frequency, low-power mode (HGO=0)	—	0.6	—	V	
	Peak-to-peak amplitude of oscillation (oscillator mode) — low-frequency, high-gain mode (HGO=1)	—	$V_{DD}$	—	V	
	Peak-to-peak amplitude of oscillation (oscillator mode) — high-frequency, low-power mode (HGO=0)	—	0.6	—	V	
	Peak-to-peak amplitude of oscillation (oscillator mode) — high-frequency, high-gain mode (HGO=1)	—	$V_{DD}$	—	V	

1.  $V_{DD}=3.3$  V, Temperature =25 °C
2. See crystal or resonator manufacturer's recommendation
3.  $C_x, C_y$  can be provided by using the integrated capacitors when the low frequency oscillator (RANGE = 00) is used. For all other cases external capacitors must be used.
4. When low power mode is selected,  $R_F$  is integrated and must not be attached externally.
5. The EXTAL and XTAL pins should only be connected to required oscillator components and must not be connected to any other devices.

### 3.3.2.2 Oscillator frequency specifications

**Table 19. Oscillator frequency specifications**

Symbol	Description	Min.	Typ.	Max.	Unit	Notes
$f_{osc\_lo}$	Oscillator crystal or resonator frequency — low-frequency mode (MCG_C2[RANGE]=00)	32	—	40	kHz	
$f_{ec\_extal}$	Input clock frequency (external clock mode)	—	—	48	MHz	1, 2
$t_{dc\_extal}$	Input clock duty cycle (external clock mode)	40	50	60	%	
$t_{cst}$	Crystal startup time — 32 kHz low-frequency, low-power mode (HGO=0)	—	1000	—	ms	3, 4

1. Other frequency limits may apply when external clock is being used as a reference for the FLL or PLL.
2. When transitioning from FEI or FBI to FBE mode, restrict the frequency of the input clock so that, when it is divided by FRDIV, it remains within the limits of the DCO input clock frequency.
3. Proper PC board layout procedures must be followed to achieve specifications.
4. Crystal startup time is defined as the time between the oscillator being enabled and the OSCINIT bit in the MCG\_S register being set.

#### NOTE

The 32 kHz oscillator works in low power mode by default and cannot be moved into high power/gain mode.

## 3.4 Memories and memory interfaces

### 3.4.1 Flash (FTFE) electrical specifications

This section describes the electrical characteristics of the FTFE module.

#### NOTE

All flash program/erase functions can only be performed when the MCU is in Normal Run mode. Programming or erasing the flash in HSRUN mode is not allowed.

#### 3.4.1.1 Flash timing specifications — program and erase

The following specifications represent the amount of time the internal charge pumps are active and do not include command overhead.

**Table 20. NVM program/erase timing specifications**

Symbol	Description	Min.	Typ.	Max.	Unit	Notes
$t_{hvp gm8}$	Program Phrase high-voltage time	—	7.5	18	$\mu$ s	
$t_{hversscr}$	Erase Flash Sector high-voltage time	—	13	113	ms	1

1. Maximum time based on expectations at cycling end-of-life.

### 3.4.1.2 Flash timing specifications — commands

**Table 21. Flash command timing specifications**

Symbol	Description	Min.	Typ.	Max.	Unit	Notes
$t_{rd1sec8k}$	Read 1s Section execution time (8 KB flash)	—	—	200	$\mu$ s	1
$t_{pgmchk}$	Program Check execution time	—	—	95	$\mu$ s	1
$t_{rdsrc}$	Read Resource execution time	—	—	40	$\mu$ s	1
$t_{pgm8}$	Program Phrase execution time	—	90	150	$\mu$ s	
$t_{ersscr}$	Erase Flash Sector execution time	—	15	115	ms	2
$t_{pgmsec1k}$	Program Section execution time (1KB flash)	—	5	—	ms	
$t_{rd1allx}$	Read 1s All Blocks execution time	—	—	1.8	ms	
$t_{rdonce}$	Read Once execution time	—	—	30	$\mu$ s	1
$t_{pgmonce}$	Program Once execution time	—	90	—	$\mu$ s	
$t_{ersall}$	Erase All Blocks execution time	—	870	7400	ms	2
$t_{vfykey}$	Verify Backdoor Access Key execution time	—	—	30	$\mu$ s	1
$t_{ersallu}$	Erase All Blocks Unsecure execution time	—	870	7400	ms	2

1. Assumes 25MHz or greater flash clock frequency.
2. Maximum times for erase parameters based on expectations at cycling end-of-life.

### 3.4.1.3 Flash high voltage current behaviors

**Table 22. Flash high voltage current behaviors**

Symbol	Description	Min.	Typ.	Max.	Unit
$I_{DD\_PGM}$	Average current adder during high voltage flash programming operation	—	3.5	7.5	mA
$I_{DD\_ERS}$	Average current adder during high voltage flash erase operation	—	1.5	4.0	mA

### 3.4.1.4 Reliability specifications

**Table 23. NVM reliability specifications**

Symbol	Description	Min.	Typ. <sup>1</sup>	Max.	Unit	Notes
Program Flash						
$t_{nvmretp10k}$	Data retention after up to 10 K cycles	5	50	—	years	

*Table continues on the next page...*

**Table 23. NVM reliability specifications (continued)**

Symbol	Description	Min.	Typ. <sup>1</sup>	Max.	Unit	Notes
$t_{nvmretp1k}$	Data retention after up to 1 K cycles	20	100	—	years	
$n_{nvmcycp}$	Cycling endurance	10 K	50 K	—	cycles	2

1. Typical data retention values are based on measured response accelerated at high temperature and derated to a constant 25°C use profile. Engineering Bulletin EB618 does not apply to this technology. Typical endurance defined in Engineering Bulletin EB619.
2. Cycling endurance represents number of program/erase cycles at  $-40^{\circ}\text{C} \leq T_j \leq 125^{\circ}\text{C}$ .

### 3.5 Flexbus switching specifications

All processor bus timings are synchronous; input setup/hold and output delay are given in respect to the rising edge of a reference clock, FB\_CLK. The FB\_CLK frequency may be the same as the internal system bus frequency or an integer divider of that frequency.

The following timing numbers indicate when data is latched or driven onto the external bus, relative to the Flexbus output clock (FB\_CLK). All other timing relationships can be derived from these values.

**Table 24. Flexbus limited voltage range switching specifications**

Num	Description	Min.	Max.	Unit	Notes
	Operating voltage	2.7	3.6	V	
	Frequency of operation	—	FB_CLK	MHz	
FB1	Clock period	1/FB_CLK	—	ns	
FB2	Address, data, and control output valid	—	11.8	ns	
FB3	Address, data, and control output hold	1.0	—	ns	1
FB4	Data and $\overline{\text{FB\_TA}}$ input setup	11.9	—	ns	
FB5	Data and $\overline{\text{FB\_TA}}$ input hold	0.0	—	ns	2

1. Specification is valid for all FB\_AD[31:0],  $\overline{\text{FB\_BE/BWEn}}$ ,  $\overline{\text{FB\_CSn}}$ , FB\_OE, FB\_R/W, FB\_TBST, FB\_TSI[1:0], FB\_ALE, and FB\_TS.
2. Specification is valid for all FB\_AD[31:0] and  $\overline{\text{FB\_TA}}$ .

**Table 25. Flexbus full voltage range switching specifications**

Num	Description	Min.	Max.	Unit	Notes
	Operating voltage	1.71	3.6	V	
	Frequency of operation	—	FB_CLK	MHz	
FB1	Clock period	1/FB_CLK	—	ns	
FB2	Address, data, and control output valid	—	12.6	ns	

Table continues on the next page...

**Table 25. Flexbus full voltage range switching specifications (continued)**

Num	Description	Min.	Max.	Unit	Notes
FB3	Address, data, and control output hold	1.0	—	ns	1
FB4	Data and $\overline{\text{FB\_TA}}$ input setup	12.5	—	ns	
FB5	Data and $\overline{\text{FB\_TA}}$ input hold	0	—	ns	2

1. Specification is valid for all  $\text{FB\_AD}[31:0]$ ,  $\overline{\text{FB\_BE/BWE}n}$ ,  $\overline{\text{FB\_CS}n}$ ,  $\overline{\text{FB\_OE}}$ ,  $\text{FB\_R/W}$ ,  $\overline{\text{FB\_TBST}}$ ,  $\text{FB\_TSIZ}[1:0]$ ,  $\text{FB\_ALE}$ , and  $\overline{\text{FB\_TS}}$ .
2. Specification is valid for all  $\text{FB\_AD}[31:0]$  and  $\overline{\text{FB\_TA}}$ .

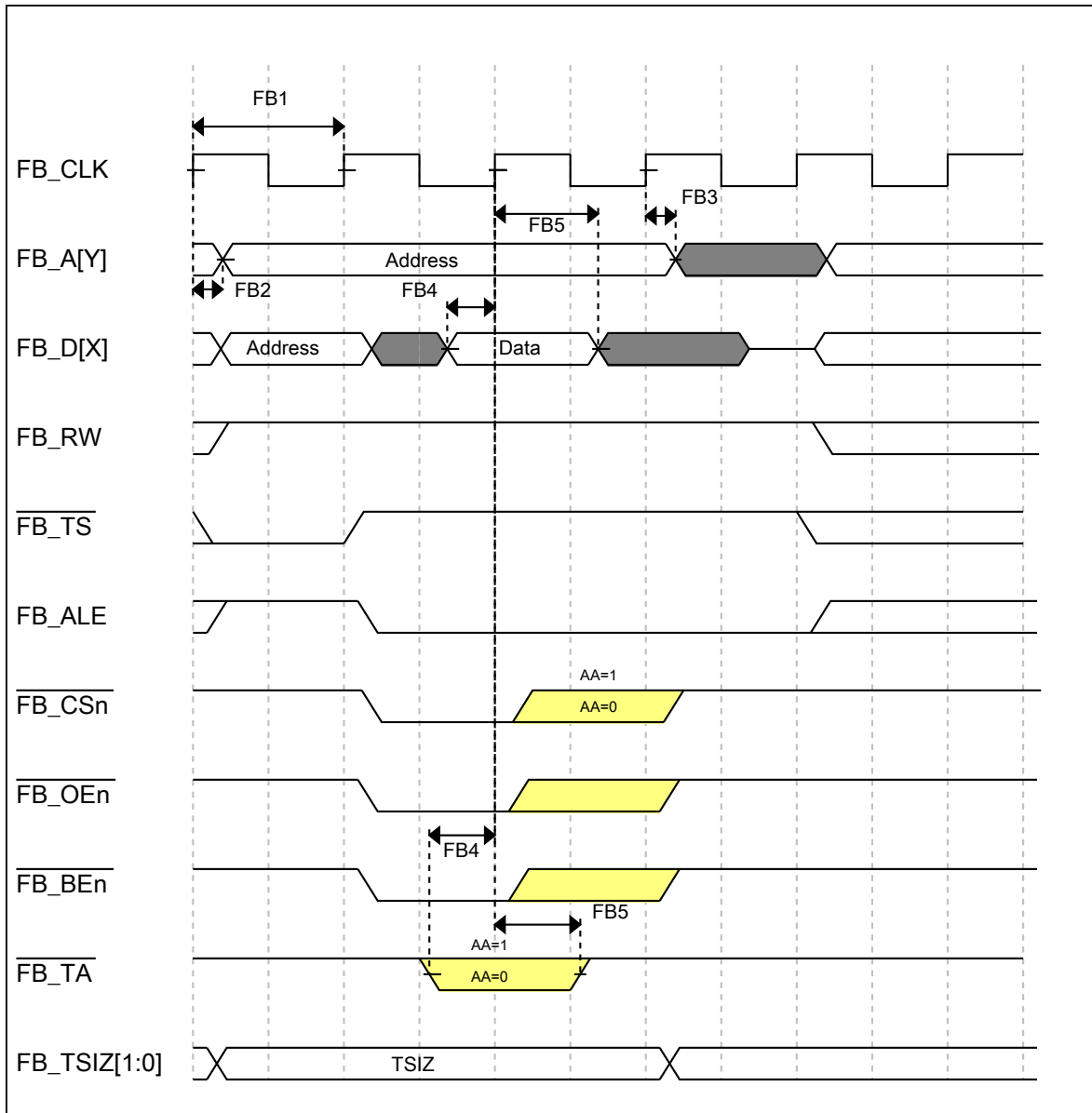

**Figure 11. FlexBus read timing diagram**

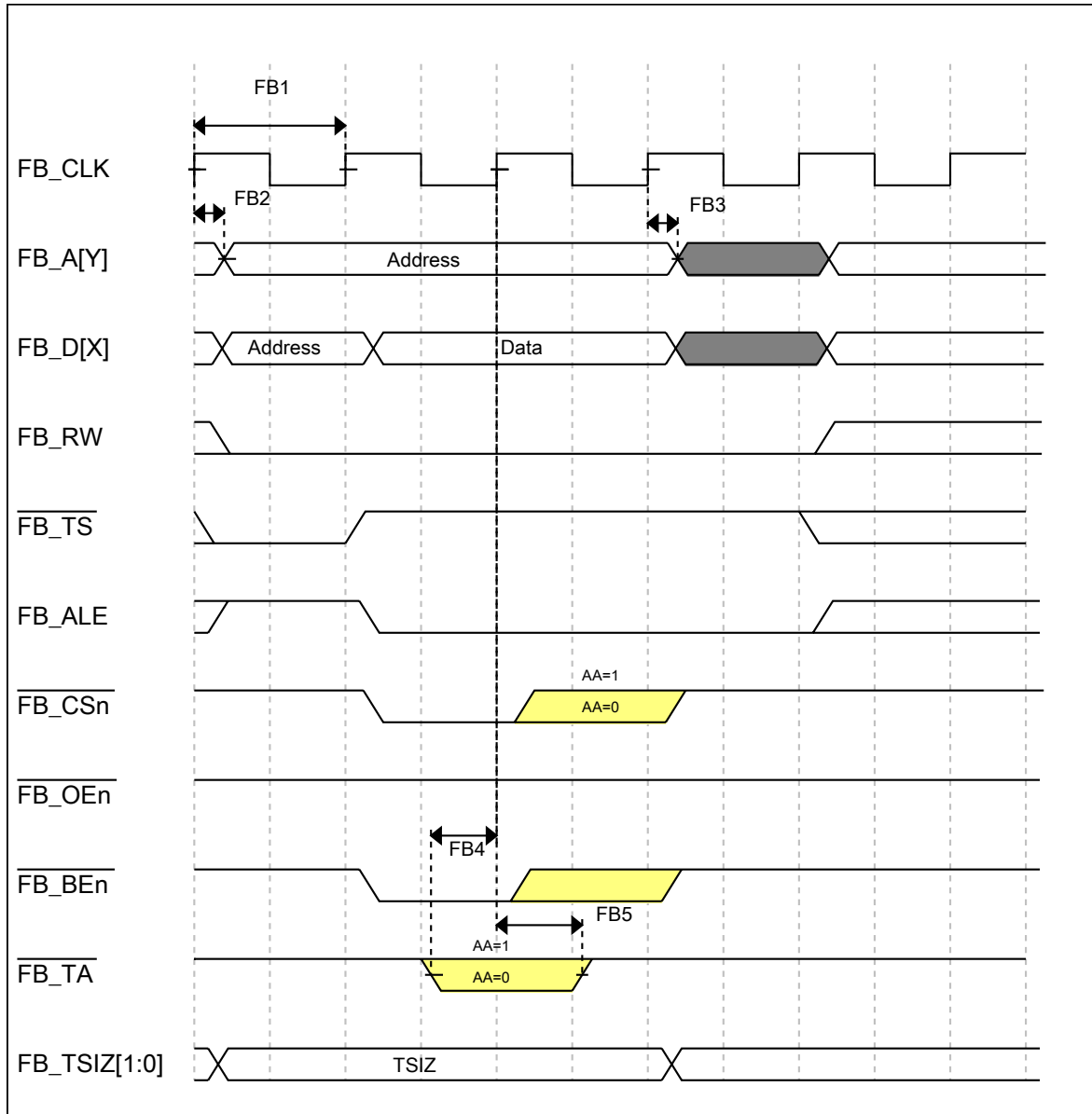

Figure 12. FlexBus write timing diagram

### 3.6 Security and integrity modules

There are no specifications necessary for the device's security and integrity modules.

### 3.7 Analog



### 3.7.1 12-bit SAR High Speed Analog-to-Digital Converter (HSADC) parameters

Table 26. 12-bit HSADC electrical specifications

Characteristic	Symbol	Min	Typ	Max	Unit
<b>Recommended Operating Conditions</b>					
Analog supply voltage	$V_{DDA}$	1.71	—	3.6	V
$V_{refh}$ Supply Voltage • $V_{DDA} \geq 2V$  • $V_{DDA} < 2V$	$V_{refh}$	2.0 $V_{DDA}$	$V_{DDA}$	$V_{DDA}$	V
$V_{refl}$ Supply Voltage	$V_{refl}$	$V_{SSA}$	$V_{SSA}$	0.1	V
<b>Analog Input</b>					
Full-scale input range (single-ended mode)		$V_{refl}$		$V_{refh}$	V
Full-scale input range (differential mode)		$2*(V_{refh} - V_{refl})$			V
Input signal common mode (only for differential mode)		$(V_{refh} + V_{refl})/2$			V
Input sampling capacitance (no parasitic capacitances included)	$C_s$		5		pF
<b>Current Consumption</b>					
$F_s=5\text{MSPS}$ (Conversion in progress, differential mode) <sup>1</sup> • $I_{DDA}$  • $I_{DD}$		— —	1150 85	— —	$\mu\text{A}$
$F_s=1\text{MSPS}$ (Conversion in progress, differential mode) <sup>1</sup> • $I_{DDA}$  • $I_{DD}$		— —	260 19	— —	$\mu\text{A}$
$F_s=10\text{kSPS}$ (Conversion in progress, differential mode) <sup>1</sup> • $I_{DDA}$  • $I_{DD}$		— —	19 2.9	— —	$\mu\text{A}$
$F_s=5\text{MSPS}$ (Conversion in progress, single-ended mode) <sup>1</sup> • $I_{DDA}$  • $I_{DD}$		— —	1030 85	— —	$\mu\text{A}$
$F_s=1\text{MSPS}$ (Conversion in progress, single-ended mode) <sup>1</sup> • $I_{DDA}$  • $I_{DD}$		— —	230 18	— —	$\mu\text{A}$
$F_s=10\text{kSPS}$ (Conversion in progress, single-ended mode) <sup>1</sup>					$\mu\text{A}$

Table continues on the next page...

**Table 26. 12-bit HSADC electrical specifications (continued)**

Characteristic	Symbol	Min	Typ	Max	Unit
<ul style="list-style-type: none"> <li>• I<sub>DDA</sub></li> <li>• I<sub>DD</sub></li> </ul>		—	19	—	
F <sub>S</sub> =5MSPS (Conversion not in progress)					μA
<ul style="list-style-type: none"> <li>• I<sub>DDA</sub></li> <li>• I<sub>DD</sub></li> </ul>		—	38	—	
		—	57	—	
F <sub>S</sub> =1MSPS (Conversion not in progress)					μA
<ul style="list-style-type: none"> <li>• I<sub>DDA</sub></li> <li>• I<sub>DD</sub></li> </ul>		—	22	—	
		—	14	—	
F <sub>S</sub> =10kSPS (Conversion not in progress)					μA
<ul style="list-style-type: none"> <li>• I<sub>DDA</sub></li> <li>• I<sub>DD</sub></li> </ul>		—	19	—	
		—	2.7	—	
<b>Timing Characteristics</b>					
Input clock frequency	f <sub>clk</sub>	0.14	70	80	MHz
Input clock frequency during calibration	f <sub>clk</sub>	0.14	—	60	MHz
Sampling rate <sup>2</sup>	F <sub>s</sub>				MSPS
<ul style="list-style-type: none"> <li>• ADCRES=11 (12 bits conversion result)</li> <li>• ADCRES=10 (10 bits conversion result)</li> <li>• ADCRES=01 (8 bits conversion result)</li> <li>• ADCRES=00 (6 bits conversion result)</li> </ul>		0.01	5	5.71	
		0.012	5.83	6.66	
		0.014	7	8	
		0.0175	8.75	10	
Conversion cycle <sup>2</sup> (back to back)					Clock cycles
<ul style="list-style-type: none"> <li>• ADCRES=11 (12 bits conversion result)</li> <li>• ADCRES=10 (10 bits conversion result)</li> <li>• ADCRES=01 (8 bits conversion result)</li> <li>• ADCRES=00 (6 bits conversion result)</li> </ul>		14			
		12			
		10			
		8			
Data latency <sup>2</sup>					Clock cycles
<ul style="list-style-type: none"> <li>• ADCRES=11 (12 bits conversion result)</li> <li>• ADCRES=10 (10 bits conversion result)</li> <li>• ADCRES=01 (8 bits conversion result)</li> <li>• ADCRES=00 (6 bits conversion result)</li> </ul>			12.5		
			10.5		
			8.5		
			6.5		
<b>Accuracy (DC or Absolute)</b>					
Integral non-Linearity	INL			+/- 2.0	LSB
Differential non-Linearity	DNL			+/- 1.0	LSB

Table continues on the next page...

**Table 26. 12-bit HSADC electrical specifications (continued)**

Characteristic	Symbol	Min	Typ	Max	Unit
Signal-to-noise and distortion ratio <sup>3</sup>	SINAD		65		dBFS
Offset error (calibration enabled)				+/- 2.0	LSB
Offset error (calibration disabled)				+/- 64	LSB
Total unadjusted error (calibration enabled)	TUE			+/- 5	LSB

1. Successive conversion mode
2. "ADCRES" refers to the resolution selection control signal
3. Value measured with a -0.5dBFS input signal and then extrapolated to full scale.

### 3.7.2 ADC electrical specifications

The 16-bit accuracy specifications listed in [Table 1](#) and [Table 28](#) are achievable on the differential pins ADC<sub>x</sub>\_DP0, ADC<sub>x</sub>\_DM0.

All other ADC channels meet the 13-bit differential/12-bit single-ended accuracy specifications.

#### 3.7.2.1 16-bit ADC operating conditions

**Table 27. 16-bit ADC operating conditions**

Symbol	Description	Conditions	Min.	Typ. <sup>1</sup>	Max.	Unit	Notes
V <sub>DDA</sub>	Supply voltage	Absolute	1.71	—	3.6	V	
ΔV <sub>DDA</sub>	Supply voltage	Delta to V <sub>DD</sub> (V <sub>DD</sub> - V <sub>DDA</sub> )	-100	0	+100	mV	2
ΔV <sub>SSA</sub>	Ground voltage	Delta to V <sub>SS</sub> (V <sub>SS</sub> - V <sub>SSA</sub> )	-100	0	+100	mV	2
V <sub>REFH</sub>	ADC reference voltage high		1.13	V <sub>DDA</sub>	V <sub>DDA</sub>	V	
V <sub>REFL</sub>	ADC reference voltage low		V <sub>SSA</sub>	V <sub>SSA</sub>	V <sub>SSA</sub>	V	
V <sub>ADIN</sub>	Input voltage		V <sub>REFL</sub>	—	V <sub>REFH</sub>	V	
C <sub>ADIN</sub>	Input capacitance	<ul style="list-style-type: none"> <li>• 16-bit mode</li> <li>• 8-bit / 10-bit / 12-bit modes</li> </ul>	—	8	10	pF	
R <sub>ADIN</sub>	Input series resistance		—	2	5	kΩ	
R <sub>AS</sub>	Analog source resistance (external)	13-bit / 12-bit modes f <sub>ADCK</sub> < 4 MHz	—	—	5	kΩ	3

Table continues on the next page...

**Table 27. 16-bit ADC operating conditions (continued)**

Symbol	Description	Conditions	Min.	Typ. <sup>1</sup>	Max.	Unit	Notes
f <sub>ADCK</sub>	ADC conversion clock frequency	≤ 13-bit mode	1.0	—	24.0	MHz	4
f <sub>ADCK</sub>	ADC conversion clock frequency	16-bit mode	2.0	—	12.0	MHz	4
C <sub>rate</sub>	ADC conversion rate	≤ 13-bit modes No ADC hardware averaging Continuous conversions enabled, subsequent conversion time	20.000	—	818.330	ksps	5
C <sub>rate</sub>	ADC conversion rate	16-bit mode No ADC hardware averaging Continuous conversions enabled, subsequent conversion time	37.037	—	461.467	ksps	5

1. Typical values assume V<sub>DDA</sub> = 3.0 V, Temp = 25 °C, f<sub>ADCK</sub> = 1.0 MHz, unless otherwise stated. Typical values are for reference only, and are not tested in production.
2. DC potential difference.
3. This resistance is external to MCU. To achieve the best results, the analog source resistance must be kept as low as possible. The results in this data sheet were derived from a system that had < 8 Ω analog source resistance. The R<sub>AS</sub>/C<sub>AS</sub> time constant should be kept to < 1 ns.
4. To use the maximum ADC conversion clock frequency, CFG2[ADHSC] must be set and CFG1[ADLPC] must be clear.
5. For guidelines and examples of conversion rate calculation, download the [ADC calculator tool](#).

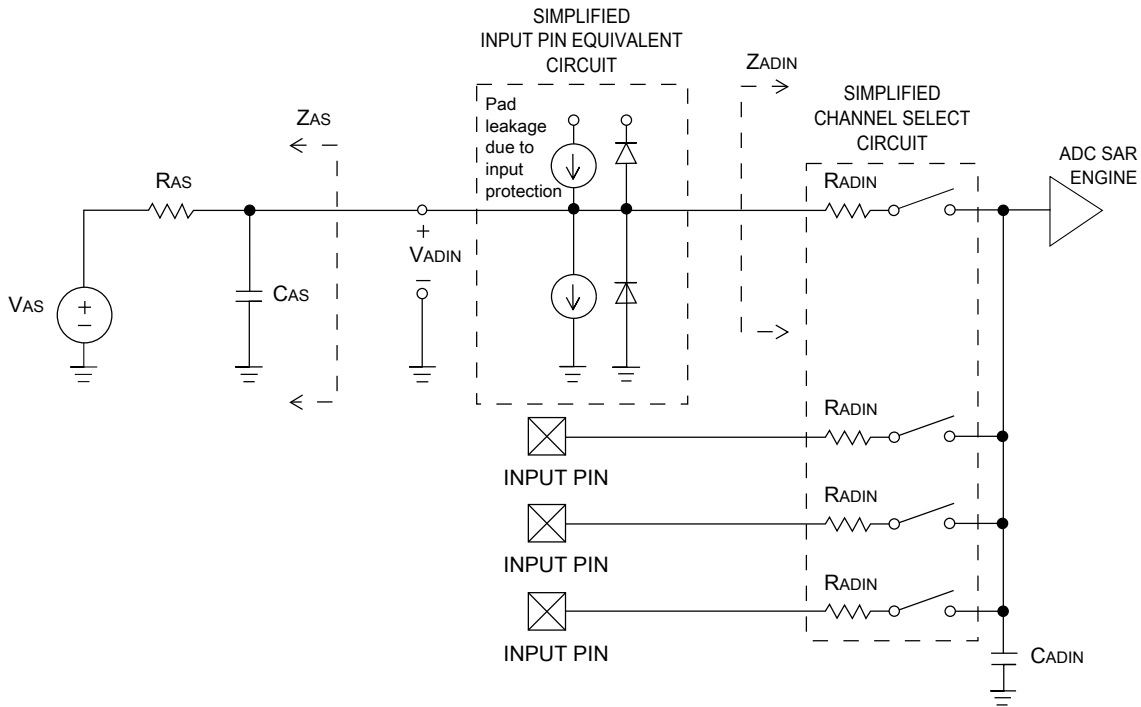

Figure 13. ADC input impedance equivalency diagram

### 3.7.2.2 16-bit ADC electrical characteristics

Table 28. 16-bit ADC characteristics ( $V_{REFH} = V_{DDA}$ ,  $V_{REFL} = V_{SSA}$ )

Symbol	Description	Conditions <sup>1</sup>	Min.	Typ. <sup>2</sup>	Max.	Unit	Notes
$I_{DDA\_ADC}$	Supply current		0.215	—	1.7	mA	3
$f_{ADACK}$	ADC asynchronous clock source	• ADLPC = 1, ADHSC = 0	1.2	2.4	3.9	MHz	$t_{ADACK} = 1/f_{ADACK}$
		• ADLPC = 1, ADHSC = 1	2.4	4.0	6.1	MHz	
		• ADLPC = 0, ADHSC = 0	3.0	5.2	7.3	MHz	
		• ADLPC = 0, ADHSC = 1	4.4	6.2	9.5	MHz	
	Sample Time	See Reference Manual chapter for sample times					
TUE	Total unadjusted error	• 12-bit modes • <12-bit modes	—	±4 ±1.4	±6.8 ±2.1	LSB <sup>4</sup>	5
DNL	Differential non-linearity	• 12-bit modes • <12-bit modes	—	±0.7 ±0.2	-1.1 to +1.9 -0.3 to 0.5	LSB <sup>4</sup>	5
INL	Integral non-linearity	• 12-bit modes	—	±1.0	-2.7 to +1.9	LSB <sup>4</sup>	5

Table continues on the next page...

**Table 28. 16-bit ADC characteristics ( $V_{REFH} = V_{DDA}$ ,  $V_{REFL} = V_{SSA}$ ) (continued)**

Symbol	Description	Conditions <sup>1</sup>	Min.	Typ. <sup>2</sup>	Max.	Unit	Notes
		<ul style="list-style-type: none"> <li>&lt;12-bit modes</li> </ul>	—	±0.5	-0.7 to +0.5		
$E_{FS}$	Full-scale error	<ul style="list-style-type: none"> <li>12-bit modes</li> <li>&lt;12-bit modes</li> </ul>	—	-4	-5.4	LSB <sup>4</sup>	$V_{ADIN} = V_{DDA}$ <sup>5</sup>
$E_Q$	Quantization error	<ul style="list-style-type: none"> <li>16-bit modes</li> <li>≤13-bit modes</li> </ul>	—	-1 to 0	—	LSB <sup>4</sup>	
ENOB	Effective number of bits	16-bit differential mode					6
		<ul style="list-style-type: none"> <li>Avg = 32</li> </ul>	12.8	14.5	—	bits	
		<ul style="list-style-type: none"> <li>Avg = 4</li> </ul>	11.9	13.8	—	bits	
		16-bit single-ended mode					
<ul style="list-style-type: none"> <li>Avg = 32</li> </ul>	12.2	13.9	—	bits			
<ul style="list-style-type: none"> <li>Avg = 4</li> </ul>	11.4	13.1	—	bits			
SINAD	Signal-to-noise plus distortion	See ENOB	6.02 × ENOB + 1.76			dB	
THD	Total harmonic distortion	16-bit differential mode				dB	7
		<ul style="list-style-type: none"> <li>Avg = 32</li> </ul>	—	-94	—	dB	
		16-bit single-ended mode				dB	
		<ul style="list-style-type: none"> <li>Avg = 32</li> </ul>	—	-85	—		
SFDR	Spurious free dynamic range	16-bit differential mode				dB	7
		<ul style="list-style-type: none"> <li>Avg = 32</li> </ul>	82	95	—	dB	
		16-bit single-ended mode				dB	
		<ul style="list-style-type: none"> <li>Avg = 32</li> </ul>	78	90	—		
$E_{IL}$	Input leakage error		$I_{in} \times R_{AS}$			mV	$I_{in}$ = leakage current (refer to the MCU's voltage and current operating ratings)
	Temp sensor slope	Across the full temperature range of the device	1.55	1.62	1.69	mV/°C	8
$V_{TEMP25}$	Temp sensor voltage	25 °C	706	716	726	mV	8

1. All accuracy numbers assume the ADC is calibrated with  $V_{REFH} = V_{DDA}$

2. Typical values assume  $V_{DDA} = 3.0$  V, Temp = 25 °C,  $f_{ADCK} = 2.0$  MHz unless otherwise stated. Typical values are for reference only and are not tested in production.

3. The ADC supply current depends on the ADC conversion clock speed, conversion rate and ADC\_CFG1[ADLPC] (low power). For lowest power operation, ADC\_CFG1[ADLPC] must be set, the ADC\_CFG2[ADHSC] bit must be clear with 1 MHz ADC conversion clock speed.
4.  $1 \text{ LSB} = (V_{\text{REFH}} - V_{\text{REFL}})/2^N$
5. ADC conversion clock < 16 MHz, Max hardware averaging (AVGE = %1, AVGS = %11)
6. Input data is 100 Hz sine wave. ADC conversion clock < 12 MHz.
7. Input data is 1 kHz sine wave. ADC conversion clock < 12 MHz.
8. ADC conversion clock < 3 MHz

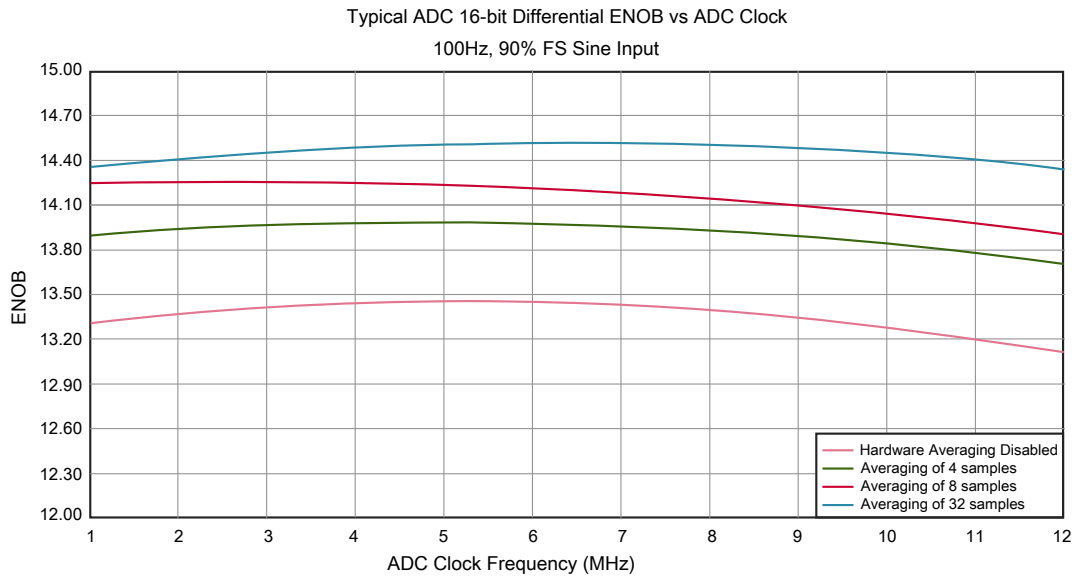

**Figure 14. Typical ENOB vs. ADC\_CLK for 16-bit differential mode**

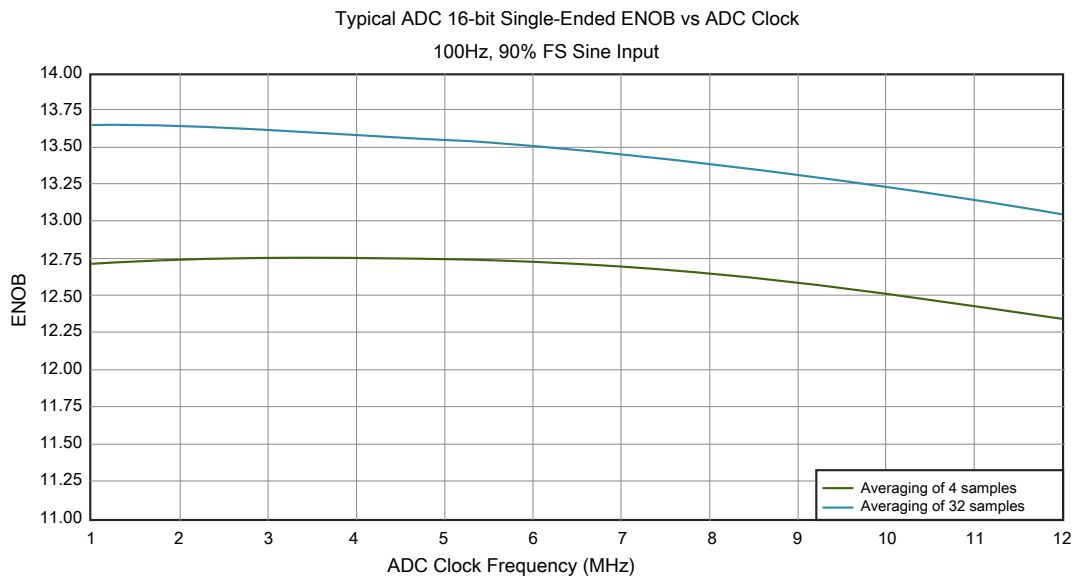

**Figure 15. Typical ENOB vs. ADC\_CLK for 16-bit single-ended mode**

### 3.7.3 CMP and 6-bit DAC electrical specifications

**Table 29. Comparator and 6-bit DAC electrical specifications**

Symbol	Description	Min.	Typ.	Max.	Unit
$V_{DD}$	Supply voltage	1.71	—	3.6	V
$I_{DDHS}$	Supply current, high-speed mode (EN = 1, PMODE = 1)	—	—	200	$\mu$ A
$I_{DDL S}$	Supply current, low-speed mode (EN = 1, PMODE = 0)	—	—	20	$\mu$ A
$V_{AIN}$	Analog input voltage	$V_{SS}$	—	$V_{DD}$	V
$V_{AIO}$	Analog input offset voltage	—	—	20	mV
$V_H$	Analog comparator hysteresis <sup>1</sup> <ul style="list-style-type: none"> <li>• CR0[HYSTCTR] = 00</li> <li>• CR0[HYSTCTR] = 01</li> <li>• CR0[HYSTCTR] = 10</li> <li>• CR0[HYSTCTR] = 11</li> </ul>	—	5	—	mV
		—	10	—	mV
		—	20	—	mV
		—	30	—	mV
$V_{CMPOh}$	Output high	$V_{DD} - 0.5$	—	—	V
$V_{CMPOl}$	Output low	—	—	0.5	V
$t_{DHS}$	Propagation delay, high-speed mode (EN = 1, PMODE = 1)	20	50	200	ns
$t_{DLS}$	Propagation delay, low-speed mode (EN = 1, PMODE = 0)	80	250	600	ns
	Analog comparator initialization delay <sup>2</sup>	—	—	40	$\mu$ s
$I_{DAC6b}$	6-bit DAC current adder (enabled)	—	7	—	$\mu$ A
INL	6-bit DAC integral non-linearity	-0.5	—	0.5	LSB <sup>3</sup>
DNL	6-bit DAC differential non-linearity	-0.3	—	0.3	LSB

1. Typical hysteresis is measured with input voltage range limited to 0.7 to  $V_{DD} - 0.7$  V.
2. Comparator initialization delay is defined as the time between software writes to change control inputs (writes to DACEN, VRSEL, PSEL, MSEL, VOSEL) and the comparator output settling to a stable level.
3. 1 LSB =  $V_{reference}/64$



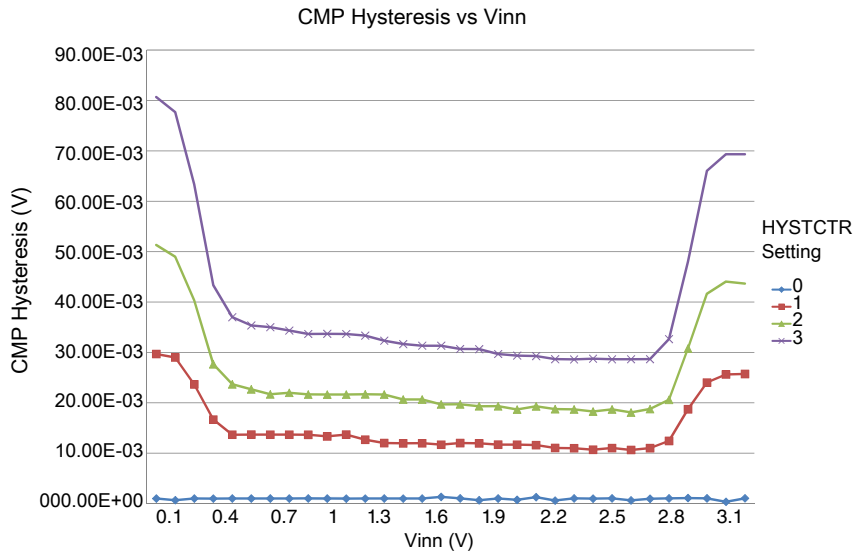

Figure 16. Typical hysteresis vs. Vin level ( $V_{DD} = 3.3\text{ V}$ ,  $P_{MODE} = 0$ )

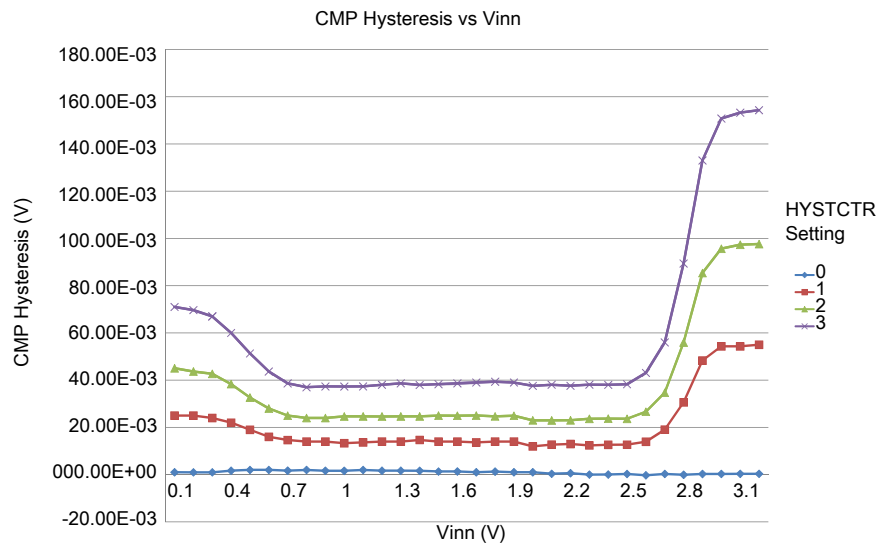

Figure 17. Typical hysteresis vs. Vin level ( $V_{DD} = 3.3\text{ V}$ ,  $P_{MODE} = 1$ )

### 3.7.4 12-bit DAC electrical characteristics

### 3.7.4.1 12-bit DAC operating requirements

Table 30. 12-bit DAC operating requirements

Symbol	Description	Min.	Max.	Unit	Notes
V <sub>DDA</sub>	Supply voltage		3.6	V	
V <sub>DACR</sub>	Reference voltage	1.13	3.6	V	1
C <sub>L</sub>	Output load capacitance	—	100	pF	2
I <sub>L</sub>	Output load current	—	1	mA	

1. The DAC reference can be selected to be V<sub>DDA</sub> or V<sub>REFH</sub>.
2. A small load capacitance (47 pF) can improve the bandwidth performance of the DAC.

### 3.7.4.2 12-bit DAC operating behaviors

Table 31. 12-bit DAC operating behaviors

Symbol	Description	Min.	Typ.	Max.	Unit	Notes
I <sub>DDA_DACL</sub> P	Supply current — low-power mode	—	—	150	μA	
I <sub>DDA_DACH</sub> P	Supply current — high-speed mode	—	—	700	μA	
t <sub>DACLP</sub>	Full-scale settling time (0x080 to 0xF7F) — low-power mode	—	100	200	μs	1
t <sub>DACHP</sub>	Full-scale settling time (0x080 to 0xF7F) — high-power mode	—	15	30	μs	1
t <sub>CCDACLP</sub>	Code-to-code settling time (0xBF8 to 0xC08) • High-speed mode • Low speed mode	—	1	5	μs	1
V <sub>dacoutl</sub>	DAC output voltage range low — high-speed mode, no load, DAC set to 0x000	—	—	100	mV	
V <sub>dacouth</sub>	DAC output voltage range high — high-speed mode, no load, DAC set to 0xFFF	V <sub>DACR</sub> - 100	—	V <sub>DACR</sub>	mV	
INL	Integral non-linearity error — high speed mode	—	—	±8	LSB	2
DNL	Differential non-linearity error — V <sub>DACR</sub> > 2 V	—	—	±1	LSB	3
DNL	Differential non-linearity error — V <sub>DACR</sub> = VREF_OUT	—	—	±1	LSB	4
V <sub>OFFSET</sub>	Offset error	—	±0.4	±0.8	%FSR	5
E <sub>G</sub>	Gain error	—	±0.1	±0.6	%FSR	5
PSRR	Power supply rejection ratio, V <sub>DDA</sub> ≥ 2.4 V	60	—	90	dB	
T <sub>CO</sub>	Temperature coefficient offset voltage	—	3.7	—	μV/C	6
T <sub>GE</sub>	Temperature coefficient gain error	—	0.000421	—	%FSR/C	
R <sub>op</sub>	Output resistance (load = 3 kΩ)	—	—	250	Ω	
SR	Slew rate -80h → F7Fh → 80h				V/μs	

Table continues on the next page...

**Table 31. 12-bit DAC operating behaviors (continued)**

Symbol	Description	Min.	Typ.	Max.	Unit	Notes
	<ul style="list-style-type: none"> <li>High power (SP<sub>HP</sub>)</li> <li>Low power (SP<sub>LP</sub>)</li> </ul>	1.2	1.7	—		
	<ul style="list-style-type: none"> <li>High power (SP<sub>HP</sub>)</li> <li>Low power (SP<sub>LP</sub>)</li> </ul>	0.05	0.12	—		
BW	3dB bandwidth				kHz	
	<ul style="list-style-type: none"> <li>High power (SP<sub>HP</sub>)</li> <li>Low power (SP<sub>LP</sub>)</li> </ul>	550	—	—		
	<ul style="list-style-type: none"> <li>High power (SP<sub>HP</sub>)</li> <li>Low power (SP<sub>LP</sub>)</li> </ul>	40	—	—		

1. Settling within  $\pm 1$  LSB
2. The INL is measured for 0 + 100 mV to  $V_{DACR} - 100$  mV
3. The DNL is measured for 0 + 100 mV to  $V_{DACR} - 100$  mV
4. The DNL is measured for 0 + 100 mV to  $V_{DACR} - 100$  mV with  $V_{DDA} > 2.4$  V
5. Calculated by a best fit curve from  $V_{SS} + 100$  mV to  $V_{DACR} - 100$  mV
6.  $V_{DDA} = 3.0$  V, reference select set for  $V_{DDA}$  (DAC<sub>X</sub>\_CO:DACRFS = 1), high power mode (DAC<sub>X</sub>\_CO:LPEN = 0), DAC set to 0x800, temperature range is across the full range of the device

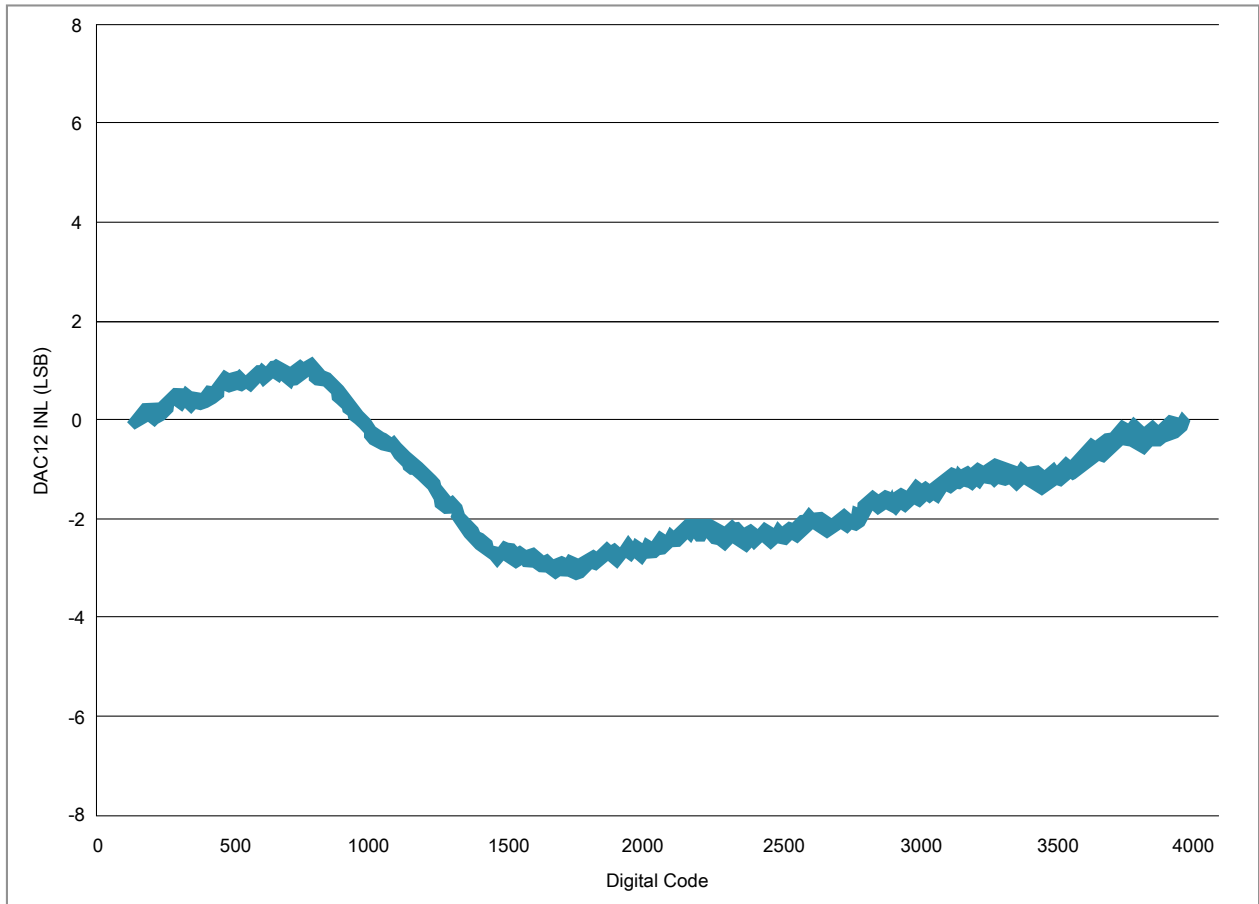

**Figure 18. Typical INL error vs. digital code**

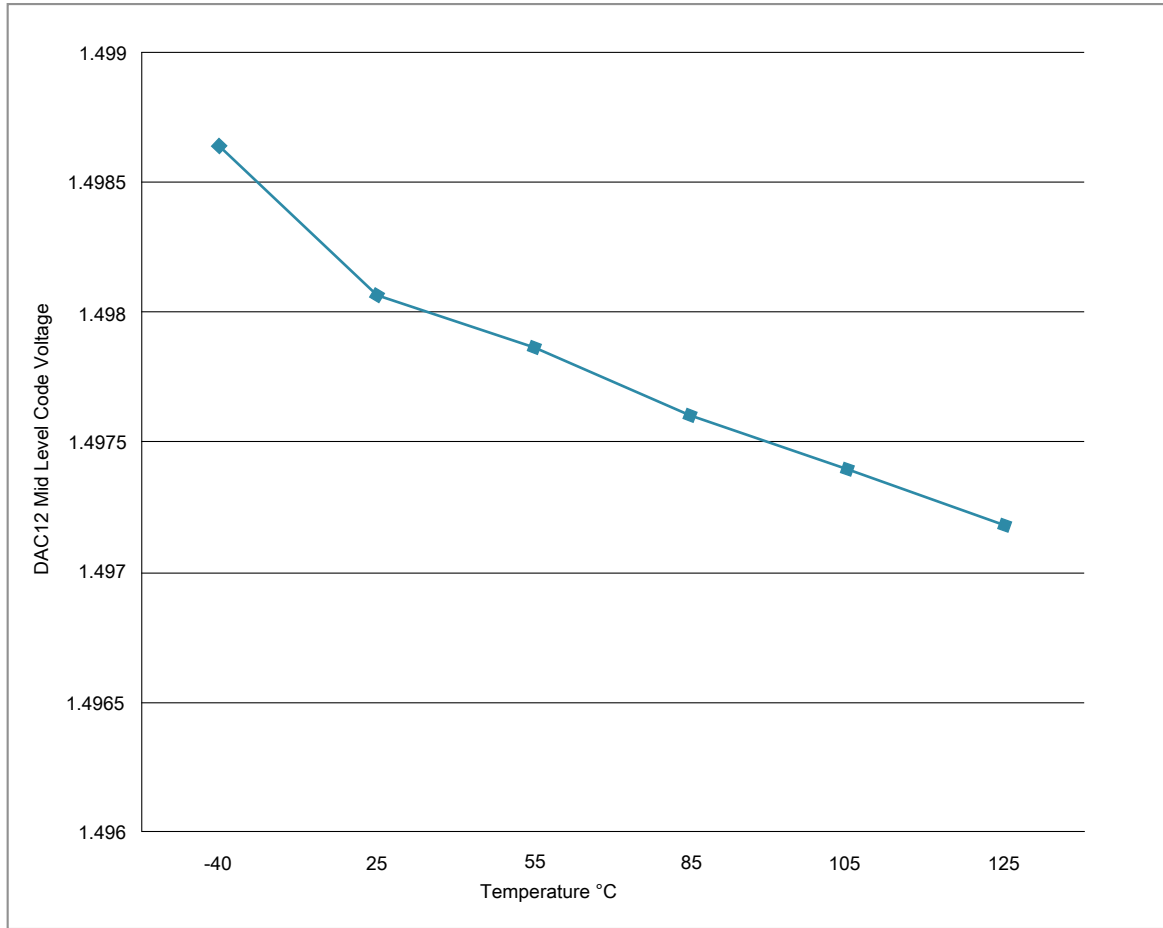

Figure 19. Offset at half scale vs. temperature

### 3.8 Timers

See [General switching specifications](#).

### 3.9 Communication interfaces

#### 3.9.1 CAN switching specifications

See [General switching specifications](#).

## 3.9.2 Ethernet switching specifications

The following timing specs are defined at the chip I/O pin and must be translated appropriately to arrive at timing specs/constraints for the physical interface.

### 3.9.2.1 MII signal switching specifications

The following timing specs meet the requirements for MII style interfaces for a range of transceiver devices.

**Table 32. MII signal switching specifications**

Symbol	Description	Min.	Max.	Unit
—	Operating Voltage	1.71	3.6	V
—	RXCLK frequency	—	25	MHz
MII1	RXCLK pulse width high	35%	65%	RXCLK period
MII2	RXCLK pulse width low	35%	65%	RXCLK period
MII3	RXD[3:0], RXDV, RXER to RXCLK setup	5	—	ns
MII4	RXCLK to RXD[3:0], RXDV, RXER hold	5	—	ns
—	TXCLK frequency	—	25	MHz
MII5	TXCLK pulse width high	35%	65%	TXCLK period
MII6	TXCLK pulse width low	35%	65%	TXCLK period
MII7	TXCLK to TXD[3:0], TXEN, TXER invalid	2	—	ns
MII8	TXCLK to TXD[3:0], TXEN, TXER valid	—	25	ns

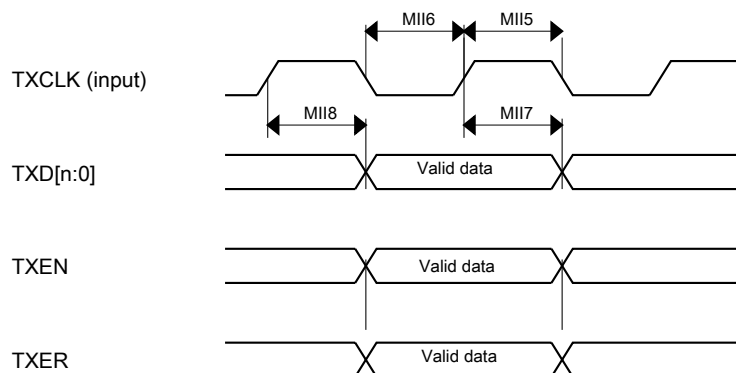

**Figure 20. RMII/MII transmit signal timing diagram**

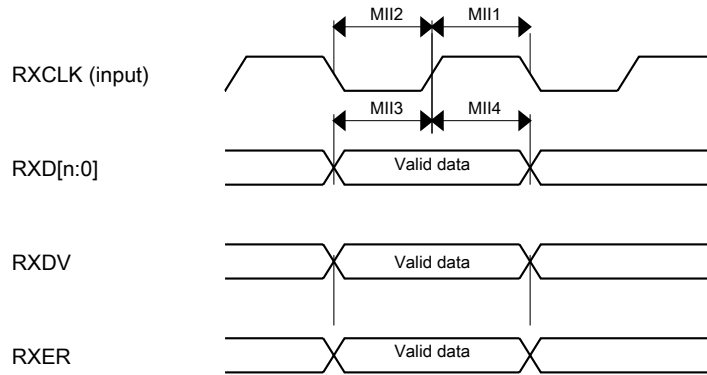

**Figure 21. RMII/MII receive signal timing diagram**

### 3.9.2.2 RMII signal switching specifications

The following timing specs meet the requirements for RMII style interfaces for a range of transceiver devices.

**Table 33. RMII signal switching specifications**

Num	Description	Min.	Max.	Unit
—	Operating Voltage	1.71	3.6	
—	EXTAL frequency (RMII input clock RMII_CLK)	—	50	MHz
RMII1	RMII_CLK pulse width high	35%	65%	RMII_CLK period
RMII2	RMII_CLK pulse width low	35%	65%	RMII_CLK period
RMII3	RXD[1:0], CRS_DV, RXER to RMII_CLK setup	4	—	ns
RMII4	RMII_CLK to RXD[1:0], CRS_DV, RXER hold	2	—	ns
RMII7	RMII_CLK to TXD[1:0], TXEN invalid	4	—	ns
RMII8	RMII_CLK to TXD[1:0], TXEN valid	—	15.4	ns

### 3.9.3 DSPI switching specifications (limited voltage range)

The DMA Serial Peripheral Interface (DSPI) provides a synchronous serial bus with master and slave operations. Many of the transfer attributes are programmable. The tables below provide DSPI timing characteristics for classic SPI timing modes. Refer to the DSPI chapter of the Reference Manual for information on the modified transfer formats used for communicating with slower peripheral devices.

**Table 34. Master mode DSPI timing (limited voltage range)**

Num	Description	Min.	Max.	Unit	Notes
	Operating voltage	2.7	3.6	V	
	Frequency of operation	—	30	MHz	
DS1	DSPI_SCK output cycle time	$2 \times t_{\text{BUS}}$	—	ns	
DS2	DSPI_SCK output high/low time	$(t_{\text{SCK}}/2) - 2$	$(t_{\text{SCK}}/2) + 2$	ns	
DS3	DSPI_PCS <sub>n</sub> to DSPI_SCK output valid	$(t_{\text{BUS}} \times 2) - 2$	—	ns	1
DS4	DSPI_SCK to DSPI_PCS <sub>n</sub> output hold	$(t_{\text{BUS}} \times 2) - 2$	—	ns	2
DS5	DSPI_SCK to DSPI_SOUT valid	—	8.5	ns	
DS6	DSPI_SCK to DSPI_SOUT invalid	-2	—	ns	
DS7	DSPI_SIN to DSPI_SCK input setup	17	—	ns	
DS8	DSPI_SCK to DSPI_SIN input hold	0	—	ns	

1. The delay is programmable in SPIx\_CTARn[PSSCK] and SPIx\_CTARn[CSSCK].
2. The delay is programmable in SPIx\_CTARn[PASC] and SPIx\_CTARn[ASC].

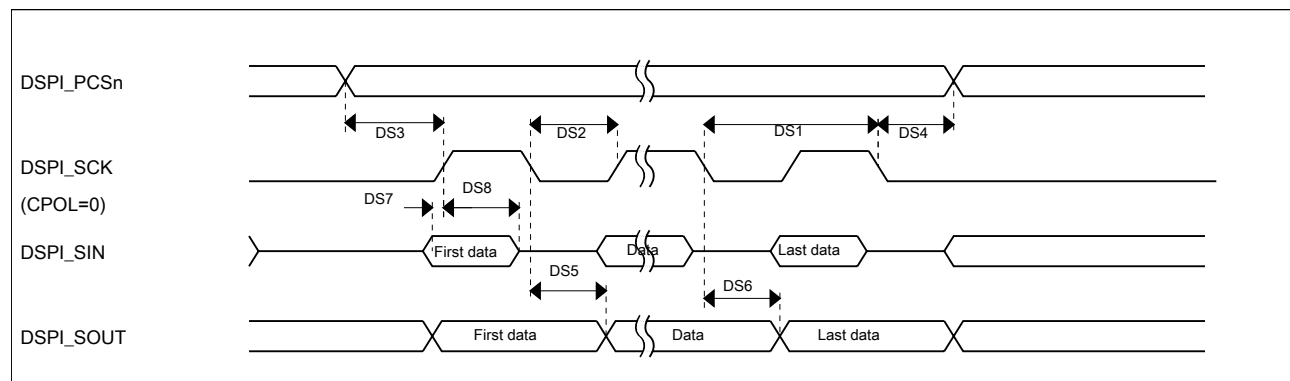

**Figure 22. DSPI classic SPI timing — master mode**

**Table 35. Slave mode DSPI timing (limited voltage range)**

Num	Description	Min.	Max.	Unit
	Operating voltage	2.7	3.6	V
	Frequency of operation		15	MHz

Table continues on the next page...

**Table 35. Slave mode DSPI timing (limited voltage range) (continued)**

Num	Description	Min.	Max.	Unit
DS9	DSPI_SCK input cycle time	$4 \times t_{BUS}$	—	ns
DS10	DSPI_SCK input high/low time	$(t_{SCK}/2) - 2$	$(t_{SCK}/2) + 2$	ns
DS11	DSPI_SCK to DSPI_SOUT valid	—	21	ns
DS12	DSPI_SCK to DSPI_SOUT invalid	0	—	ns
DS13	DSPI_SIN to DSPI_SCK input setup	2	—	ns
DS14	DSPI_SCK to DSPI_SIN input hold	7	—	ns
DS15	DSPI_SS active to DSPI_SOUT driven	—	15	ns
DS16	DSPI_SS inactive to DSPI_SOUT not driven	—	15	ns

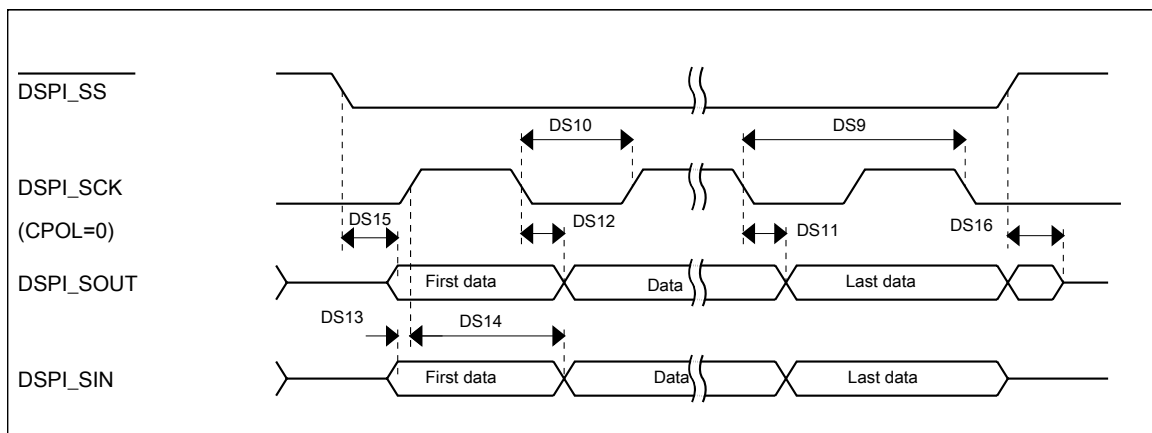

**Figure 23. DSPI classic SPI timing — slave mode**

### 3.9.4 DSPI switching specifications (full voltage range)

The DMA Serial Peripheral Interface (DSPI) provides a synchronous serial bus with master and slave operations. Many of the transfer attributes are programmable. The tables below provides DSPI timing characteristics for classic SPI timing modes. Refer to the DSPI chapter of the Reference Manual for information on the modified transfer formats used for communicating with slower peripheral devices.

**Table 36. Master mode DSPI timing (full voltage range)**

Num	Description	Min.	Max.	Unit	Notes
	Operating voltage	1.71	3.6	V	1
	Frequency of operation	—	25	MHz	
DS1	DSPI_SCK output cycle time	$4 \times t_{BUS}$	—	ns	
DS2	DSPI_SCK output high/low time	$(t_{SCK}/2) - 4$	$(t_{SCK}/2) + 4$	ns	

Table continues on the next page...



**Table 36. Master mode DSPI timing (full voltage range) (continued)**

Num	Description	Min.	Max.	Unit	Notes
DS3	DSPI_PCSn valid to DSPI_SCK delay	$(t_{BUS} \times 2) - 4$	—	ns	2
DS4	DSPI_SCK to DSPI_PCSn invalid delay	$(t_{BUS} \times 2) - 4$	—	ns	3
DS5	DSPI_SCK to DSPI_SOUT valid	—	10	ns	
DS6	DSPI_SCK to DSPI_SOUT invalid	-7.8	—	ns	
DS7	DSPI_SIN to DSPI_SCK input setup	24	—	ns	
DS8	DSPI_SCK to DSPI_SIN input hold	0	—	ns	

1. The DSPI module can operate across the entire operating voltage for the processor, but to run across the full voltage range the maximum frequency of operation is reduced.
2. The delay is programmable in SPIx\_CTARn[PSSCK] and SPIx\_CTARn[CSSCK].
3. The delay is programmable in SPIx\_CTARn[PASC] and SPIx\_CTARn[ASC].

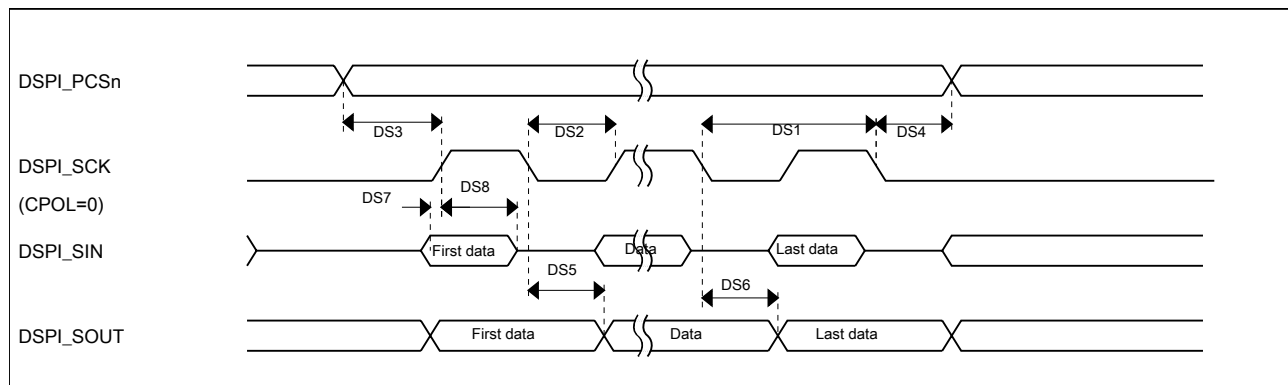
**Figure 24. DSPI classic SPI timing — master mode**
**Table 37. Slave mode DSPI timing (full voltage range)**

Num	Description	Min.	Max.	Unit
	Operating voltage	1.71	3.6	V
	Frequency of operation	—	12.5	MHz
DS9	DSPI_SCK input cycle time	$8 \times t_{BUS}$	—	ns
DS10	DSPI_SCK input high/low time	$(t_{SCK/2}) - 4$	$(t_{SCK/2}) + 4$	ns
DS11	DSPI_SCK to DSPI_SOUT valid	—	27.5	ns
DS12	DSPI_SCK to DSPI_SOUT invalid	0	—	ns
DS13	DSPI_SIN to DSPI_SCK input setup	2.5	—	ns
DS14	DSPI_SCK to DSPI_SIN input hold	7	—	ns
DS15	$\overline{DSPI\_SS}$ active to DSPI_SOUT driven	—	22	ns
DS16	$\overline{DSPI\_SS}$ inactive to DSPI_SOUT not driven	—	22	ns

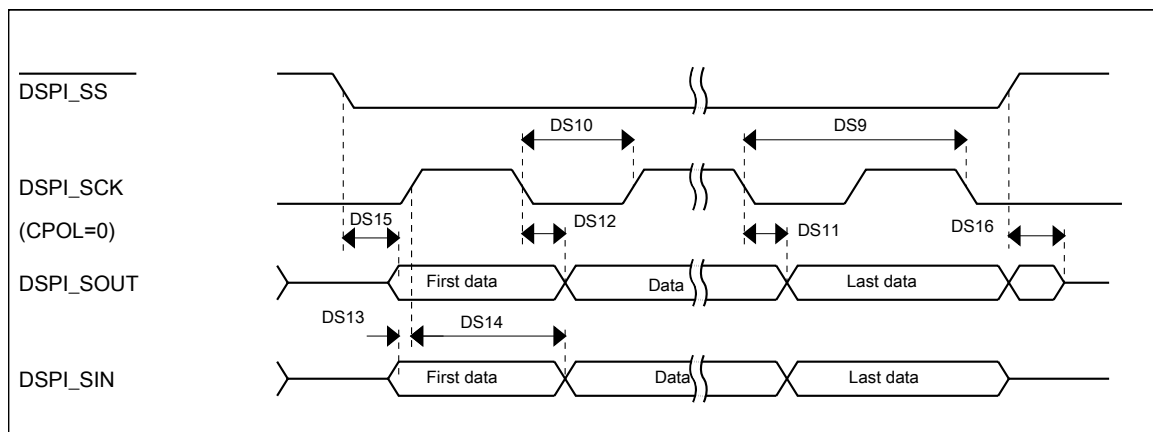

Figure 25. DSPI classic SPI timing — slave mode

### 3.9.5 I<sup>2</sup>C

See [General switching specifications](#).

### 3.9.6 UART

See [General switching specifications](#).

## 4 Dimensions

### 4.1 Obtaining package dimensions

Package dimensions are provided in package drawings.

To find a package drawing, go to [www.freescale.com](http://www.freescale.com) and perform a keyword search for the drawing's document number:

If you want the drawing for this package	Then use this document number
144-pin MAPBGA	98ASA00222D
144-pin LQFP	98ASS23177W
100-pin LQFP	98ASS23308W

## 5 Pinouts and Packaging

### 5.1 KV5x Signal Multiplexing and Pin Assignments

The following table shows the signals available on each pin and the locations of these pins on the devices supported by this document. The Port Control Module is responsible for selecting which ALT functionality is available on each pin.

144 MAP BGA	144 LQFP	100 LQFP	Pin Name	Default	ALT0	ALT1	ALT2	ALT3	ALT4	ALT5	ALT6	ALT7	ALT8	ALT9
D3	1	1	PTE0	HSADC0B_CH16/ HSADC1A_CH0	HSADC0B_CH16/ HSADC1A_CH0	PTE0	SPI1_PCS1	UART1_TX	XB_OUT10	XB_IN11	I2C1_SDA		TRACE_CLKOUT	
D2	2	2	PTE1/ LLWU_P0	HSADC0B_CH17/ HSADC1A_CH1	HSADC0B_CH17/ HSADC1A_CH1	PTE1/ LLWU_P0	SPI1_SOUT	UART1_RX	XB_OUT11	XB_IN7	I2C1_SCL		TRACE_D3	
D1	3	3	PTE2/ LLWU_P1	HSADC0B_CH10/ HSADC1B_CH0	HSADC0B_CH10/ HSADC1B_CH0	PTE2/ LLWU_P1	SPI1_SCK	UART1_CTS_b					TRACE_D2	
E4	4	4	PTE3	HSADC0B_CH11/ HSADC1B_CH1	HSADC0B_CH11/ HSADC1B_CH1	PTE3	SPI1_SIN	UART1_RTS_b					TRACE_D1	
E5	5	—	VDD	VDD	VDD									
F6	6	—	VSS	VSS	VSS									
E3	7	5	PTE4/ LLWU_P2	HSADC1A_CH4/ ADC0_SE2/ ADC0_DP2	HSADC1A_CH4/ ADC0_SE2/ ADC0_DP2	PTE4/ LLWU_P2	SPI1_PCS0	UART3_TX					TRACE_D0	
E2	8	6	PTE5	HSADC1A_CH5/ ADC0_SE10/ ADC0_DM2	HSADC1A_CH5/ ADC0_SE10/ ADC0_DM2	PTE5	SPI1_PCS2	UART3_RX		FLEXPWM1_A0	FTM3_CH0			
E1	9	7	PTE6/ LLWU_P16	HSADC1B_CH7/ ADC0_SE4a	HSADC1B_CH7/ ADC0_SE4a	PTE6/ LLWU_P16	SPI1_PCS3	UART3_CTS_b		FLEXPWM1_B0	FTM3_CH1			
F4	10	—	PTE7	DISABLED		PTE7		UART3_RTS_b		FLEXPWM1_A1	FTM3_CH2			



## Pinouts and Packaging

144 MAP BGA	144 LQFP	100 LQFP	Pin Name	Default	ALT0	ALT1	ALT2	ALT3	ALT4	ALT5	ALT6	ALT7	ALT8	ALT9
F3	11	—	PTE8	DISABLED		PTE8		UART5_TX		FLEXPWM1_B1	FTM3_CH3			
F2	12	—	PTE9/LLWU_P17	DISABLED		PTE9/LLWU_P17		UART5_RX		FLEXPWM1_A2	FTM3_CH4			
F1	13	—	PTE10/LLWU_P18	DISABLED		PTE10/LLWU_P18		UART5_CTS_b		FLEXPWM1_B2	FTM3_CH5			
G4	14	—	PTE11	HSADC1A_CH6/ ADC0_SE3/ ADC0_DP3	HSADC1A_CH6/ ADC0_SE3/ ADC0_DP3	PTE11		UART5_RTS_b		FLEXPWM1_A3	FTM3_CH6			
G3	15	—	PTE12	HSADC1B_CH6/ ADC0_SE11/ ADC0_DM3	HSADC1B_CH6/ ADC0_SE11/ ADC0_DM3	PTE12				FLEXPWM1_B3	FTM3_CH7			
E6	16	8	VDD	VDD	VDD									
F7	17	9	VSS	VSS	VSS									
H1	18	10	PTE16	HSADC0A_CH0/ ADC0_SE1/ ADC0_DP1	HSADC0A_CH0/ ADC0_SE1/ ADC0_DP1	PTE16	SPI0_PCS0	UART2_TX	FTM_CLKIN0		FTM0_FLT3			
H2	19	11	PTE17/LLWU_P19	HSADC0A_CH1/ ADC0_SE9/ ADC0_DM1	HSADC0A_CH1/ ADC0_SE9/ ADC0_DM1	PTE17/LLWU_P19	SPI0_SCK	UART2_RX	FTM_CLKIN1		LPTMR0_ALT3			
G1	20	12	PTE18/LLWU_P20	HSADC0B_CH0/ ADC0_SE5a	HSADC0B_CH0/ ADC0_SE5a	PTE18/LLWU_P20	SPI0_SOUT	UART2_CTS_b	I2C0_SDA					
G2	21	13	PTE19	HSADC0B_CH1/ ADC0_SE6a	HSADC0B_CH1/ ADC0_SE6a	PTE19	SPI0_SIN	UART2_RTS_b	I2C0_SCL		CMP3_OUT			
H3	22	—	VSS	VSS	VSS									
J1	23	14	HSADC0A_CH6	HSADC0A_CH6/ ADC0_SE7a	HSADC0A_CH6/ ADC0_SE7a									

144 MAP BGA	144 LQFP	100 LQFP	Pin Name	Default	ALT0	ALT1	ALT2	ALT3	ALT4	ALT5	ALT6	ALT7	ALT8	ALT9
J2	24	15	HSADC0A_CH7/ ADC0_SE4b	HSADC0A_CH7/ ADC0_SE4b	HSADC0A_CH7/ ADC0_SE4b									
K1	25	16	PTE20	HSADC0A_CH8/ ADC0_SE5b	HSADC0A_CH8/ ADC0_SE5b	PTE20		FTM1_CH0	UART0_TX	FTM1_QD_PHA				
K2	26	17	PTE21	HSADC0A_CH9/ HSADC1A_CH7	HSADC0A_CH9/ HSADC1A_CH7	PTE21	XB_IN9	FTM1_CH1	UART0_RX	FTM1_QD_PHB				
L1	27	18	HSADC0A_CH2/ HSADC1A_CH2	HSADC0A_CH2/ HSADC1A_CH2	HSADC0A_CH2/ HSADC1A_CH2									
L2	28	19	HSADC0A_CH3/ HSADC1A_CH3	HSADC0A_CH3/ HSADC1A_CH3	HSADC0A_CH3/ HSADC1A_CH3									
M1	29	20	HSADC0A_CH10/ HSADC1B_CH2	HSADC0A_CH10/ HSADC1B_CH2	HSADC0A_CH10/ HSADC1B_CH2									
M2	30	21	HSADC0A_CH11/ HSADC1B_CH3	HSADC0A_CH11/ HSADC1B_CH3	HSADC0A_CH11/ HSADC1B_CH3									
H5	31	22	VDDA	VDDA	VDDA									
G5	32	23	VREFH	VREFH	VREFH									
G6	33	24	VREFL	VREFL	VREFL									
H6	34	25	VSSA	VSSA	VSSA									
K3	35	—	ADC0_SE0/ ADC0_DP0/ CMP2_IN5	ADC0_SE0/ ADC0_DP0/ CMP2_IN5	ADC0_SE0/ ADC0_DP0/ CMP2_IN5									
J3	36	—	ADC0_SE8/ ADC0_DM0/ CMP1_IN2	ADC0_SE8/ ADC0_DM0/ CMP1_IN2	ADC0_SE8/ ADC0_DM0/ CMP1_IN2									
M3	37	26	PTE29	HSADC0A_CH4/ CMP1_IN5/ CMP0_IN5	HSADC0A_CH4/ CMP1_IN5/ CMP0_IN5	PTE29		FTM0_CH2		FTM_CLKIN0				
L3	38	27	PTE30	DAC0_OUT/	DAC0_OUT/	PTE30		FTM0_CH3		FTM_CLKIN1				



## Pinouts and Packaging

144 MAP BGA	144 LQFP	100 LQFP	Pin Name	Default	ALT0	ALT1	ALT2	ALT3	ALT4	ALT5	ALT6	ALT7	ALT8	ALT9
				CMP1_IN3/ HSADC0A_CH5	CMP1_IN3/ HSADC0A_CH5									
L4	39	28	HSADC0A_CH12/ CMP0_IN4/ CMP2_IN3	HSADC0A_CH12/ CMP0_IN4/ CMP2_IN3	HSADC0A_CH12/ CMP0_IN4/ CMP2_IN3									
L5	40	—	PTE13	DISABLED		PTE13								
M7	41	—	PTE22	DISABLED		PTE22		FTM2_CH0	XB_IN2	FTM2_QD_PHA				
M6	42	—	PTE23	DISABLED		PTE23		FTM2_CH1	XB_IN3	FTM2_QD_PHB				
—	—	29	VSS	VSS	VSS									
L6	43	30	VDD	VDD	VDD									
—	44	—	VSS	VSS	VSS									
M4	45	31	PTE24	HSADC0B_CH4/ HSADC1B_CH4	HSADC0B_CH4/ HSADC1B_CH4	PTE24	CAN1_TX	FTM0_CH0	XB_IN2	I2C0_SCL	EWM_OUT_b	XB_OUT4	UART4_TX	
K5	46	32	PTE25/ LLWU_P21	HSADC0B_CH5/ HSADC1B_CH5	HSADC0B_CH5/ HSADC1B_CH5	PTE25/ LLWU_P21	CAN1_RX	FTM0_CH1	XB_IN3	I2C0_SDA	EWM_IN	XB_OUT5	UART4_RX	
K4	47	33	PTE26	DISABLED		PTE26	ENET_1588_CLKIN	FTM0_CH4					UART4_CTS_b	
J4	48	—	PTE27	DISABLED		PTE27	CAN2_TX						UART4_RTS_b	
H4	49	—	PTE28	DISABLED		PTE28	CAN2_RX							
J5	50	34	PTA0	JTAG_TCLK/ SWD_CLK		PTA0	UART0_CTS_b/ UART0_COL_b	FTM0_CH5	XB_IN4	EWM_IN		JTAG_TCLK/ SWD_CLK		
J6	51	35	PTA1	JTAG_TDI		PTA1	UART0_RX	FTM0_CH6	CMP0_OUT	FTM2_QD_PHA	FTM1_CH1	JTAG_TDI		
K6	52	36	PTA2	JTAG_TDO/ TRACE_SWO		PTA2	UART0_TX	FTM0_CH7	CMP1_OUT	FTM2_QD_PHB	FTM1_CH0	JTAG_TDO/ TRACE_SWO		
K7	53	37	PTA3	JTAG_TMS/ SWD_DIO		PTA3	UART0_RTS_b	FTM0_CH0	XB_IN9	EWM_OUT_b	FLEXPWM0_A0	JTAG_TMS/ SWD_DIO		
L7	54	38	PTA4/ LLWU_P3	NMI_b		PTA4/ LLWU_P3		FTM0_CH1	XB_IN10	FTM0_FLT3	FLEXPWM0_B0	NMI_b		

144 MAP BGA	144 LQFP	100 LQFP	Pin Name	Default	ALT0	ALT1	ALT2	ALT3	ALT4	ALT5	ALT6	ALT7	ALT8	ALT9
M8	55	39	PTA5	DISABLED		PTA5		FTM0_CH2	RMII0_RXER/ MII0_RXER	CMP2_OUT		JTAG_TRST_b		
E7	56	40	VDD	VDD	VDD									
G7	57	41	VSS	VSS	VSS									
J7	58	—	PTA6	DISABLED		PTA6		FTM0_CH3		CLKOUT		TRACE_CLKOUT		
J8	59	—	PTA7	HSADC1B_CH8	HSADC1B_CH8	PTA7		FTM0_CH4		RMII0_MDIO/ MII0_MDIO		TRACE_D3		
K8	60	—	PTA8	HSADC1B_CH9	HSADC1B_CH9	PTA8		FTM1_CH0		RMII0_MDC/ MII0_MDC		TRACE_D2		
L8	61	—	PTA9	DISABLED		PTA9		FTM1_CH1		MII0_RXD3		TRACE_D1		
M9	62	—	PTA10/ LLWU_P22	DISABLED		PTA10/ LLWU_P22		FTM2_CH0		MII0_RXD2	FTM2_QD_PHA	TRACE_D0		
L9	63	—	PTA11/ LLWU_P23	DISABLED		PTA11/ LLWU_P23		FTM2_CH1		MII0_RXCLK	FTM2_QD_PHB		I2C0_SDA	
K9	64	42	PTA12	CMP2_IN0	CMP2_IN0	PTA12	CAN0_TX	FTM1_CH0		RMII0_RXD1/ MII0_RXD1		FTM1_QD_PHA	I2C0_SCL	
J9	65	43	PTA13/ LLWU_P4	CMP2_IN1	CMP2_IN1	PTA13/ LLWU_P4	CAN0_RX	FTM1_CH1		RMII0_RXD0/ MII0_RXD0		FTM1_QD_PHB	I2C1_SDA	
L10	66	44	PTA14	CMP3_IN0	CMP3_IN0	PTA14	SPI0_PCS0	UART0_TX	CAN2_TX	RMII0_CRS_DV/ MII0_RXDV			I2C1_SCL	
L11	67	45	PTA15	CMP3_IN1	CMP3_IN1	PTA15	SPI0_SCK	UART0_RX	CAN2_RX	RMII0_TXEN/ MII0_TXEN				
K10	68	46	PTA16	CMP3_IN2	CMP3_IN2	PTA16	SPI0_SOUT	UART0_CTS_b/ UART0_COL_b		RMII0_TXD0/ MII0_TXD0				
K11	69	47	PTA17	HSADC0A_CH15	HSADC0A_CH15	PTA17	SPI0_SIN	UART0_RTS_b		RMII0_TXD1/ MII0_TXD1				
E8	70	48	VDD	VDD	VDD									
G8	71	49	VSS	VSS	VSS									



## Pinouts and Packaging

144 MAP BGA	144 LQFP	100 LQFP	Pin Name	Default	ALT0	ALT1	ALT2	ALT3	ALT4	ALT5	ALT6	ALT7	ALT8	ALT9
M12	72	50	PTA18	EXTAL0	EXTAL0	PTA18	XB_IN7	FTM0_FLT2	FTM_CLKIN0	XB_OUT8	FTM3_CH2			
M11	73	51	PTA19	XTAL0	XTAL0	PTA19	XB_IN8	FTM1_FLT0	FTM_CLKIN1	XB_OUT9	LPTMR0_ALT1			
L12	74	52	RESET_b	RESET_b	RESET_b									
K12	75	—	PTA24	DISABLED		PTA24	XB_IN4			MII0_TXD2			FB_A29	
J12	76	—	PTA25	DISABLED		PTA25	XB_IN5			MII0_TXCLK			FB_A28	
J11	77	—	PTA26	DISABLED		PTA26				MII0_TXD3			FB_A27	
J10	78	—	PTA27	DISABLED		PTA27				MII0_CRS			FB_A26	
H12	79	—	PTA28	DISABLED		PTA28				MII0_TXER			FB_A25	
H11	80	—	PTA29	DISABLED		PTA29				MII0_COL			FB_A24	
H10	81	53	PTB0/LLWU_P5	HSADC0B_CH2	HSADC0B_CH2	PTB0/LLWU_P5	I2C0_SCL	FTM1_CH0			FTM1_QD_PHA	UART0_RX	RMII0_MDIO/MII0_MDIO	
H9	82	54	PTB1	HSADC0B_CH3	HSADC0B_CH3	PTB1	I2C0_SDA	FTM1_CH1	FTM0_FLT2	EWM_IN	FTM1_QD_PHB	UART0_TX	RMII0_MDC/MII0_MDC	
G12	83	55	PTB2	HSADC0A_CH14/CMP2_IN2	HSADC0A_CH14/CMP2_IN2	PTB2	I2C0_SCL	UART0_RTS_b	FTM0_FLT1	ENET0_1588_TMR0	FTM0_FLT3			
G11	84	56	PTB3	HSADC0B_CH15/CMP3_IN5	HSADC0B_CH15/CMP3_IN5	PTB3	I2C0_SDA	UART0_CTS_b/UART0_COL_b		ENET0_1588_TMR1	FTM0_FLT0			
G10	85	—	PTB4	ADC0_SE6b	ADC0_SE6b	PTB4			FLEXPWM1_X0	ENET0_1588_TMR2	FTM1_FLT0			
G9	86	—	PTB5	ADC0_SE7b	ADC0_SE7b	PTB5			FLEXPWM1_X1	ENET0_1588_TMR3	FTM2_FLT0			
F12	87	—	PTB6	HSADC1A_CH12	HSADC1A_CH12	PTB6	CAN2_TX		FLEXPWM1_X2				FB_AD23	
F11	88	—	PTB7	HSADC1A_CH13	HSADC1A_CH13	PTB7	CAN2_RX		FLEXPWM1_X3				FB_AD22	
F10	89	—	PTB8	DISABLED		PTB8		UART3_RTS_b					FB_AD21	
F9	90	57	PTB9	DISABLED		PTB9	SPI1_PCS1	UART3_CTS_b		ENET0_1588_TMR2			FB_AD20	
E12	91	58	PTB10	HSADC0B_CH6	HSADC0B_CH6	PTB10	SPI1_PCS0	UART3_RX		ENET0_1588_TMR3	FTM0_FLT1		FB_AD19	



144 MAP BGA	144 LQFP	100 LQFP	Pin Name	Default	ALT0	ALT1	ALT2	ALT3	ALT4	ALT5	ALT6	ALT7	ALT8	ALT9
E11	92	59	PTB11	HSADC0B_CH7	HSADC0B_CH7	PTB11	SPI1_SCK	UART3_TX			FTM0_FLT2		FB_AD18	
H7	93	60	VSS	VSS	VSS									
F5	94	61	VDD	VDD	VDD									
E10	95	62	PTB16	DISABLED		PTB16	SPI1_SOUT	UART0_RX	FTM_CLKIN2	CAN0_TX	EWM_IN	XB_IN5	FB_AD17	
E9	96	63	PTB17	DISABLED		PTB17	SPI1_SIN	UART0_TX	FTM_CLKIN1	CAN0_RX	EWM_OUT_b		FB_AD16	
D12	97	64	PTB18	DISABLED		PTB18	CAN0_TX	FTM2_CH0	FTM3_CH2	FLEXPWM1_A1	FTM2_QD_PHA		FB_AD15	
D11	98	65	PTB19	DISABLED		PTB19	CAN0_RX	FTM2_CH1	FTM3_CH3	FLEXPWM1_B1	FTM2_QD_PHB		FB_OE_b	
D10	99	66	PTB20	DISABLED		PTB20	SPI2_PCS0			FLEXPWM0_X0	CMP0_OUT		FB_AD31	
D9	100	67	PTB21	DISABLED		PTB21	SPI2_SCK			FLEXPWM0_X1	CMP1_OUT		FB_AD30	
C12	101	68	PTB22	DISABLED		PTB22	SPI2_SOUT			FLEXPWM0_X2	CMP2_OUT		FB_AD29	
C11	102	69	PTB23	DISABLED		PTB23	SPI2_SIN	SPI0_PCS5		FLEXPWM0_X3	CMP3_OUT		FB_AD28	
B12	103	70	PTC0	HSADC0B_CH8	HSADC0B_CH8	PTC0	SPI0_PCS4	PDB0_EXTRG			FTM0_FLT1	SPI0_PCS0	FB_AD14	
B11	104	71	PTC1/LLWU_P6	HSADC0B_CH9	HSADC0B_CH9	PTC1/LLWU_P6	SPI0_PCS3	UART1_RTS_b	FTM0_CH0	FLEXPWM0_A3	XB_IN11		FB_AD13	
A12	105	72	PTC2	HSADC1B_CH10/ CMP1_IN0	HSADC1B_CH10/ CMP1_IN0	PTC2	SPI0_PCS2	UART1_CTS_b	FTM0_CH1	FLEXPWM0_B3	XB_IN6		FB_AD12	
A11	106	73	PTC3/LLWU_P7	CMP1_IN1	CMP1_IN1	PTC3/LLWU_P7	SPI0_PCS1	UART1_RX	FTM0_CH2	CLKOUT	FTM3_FLT0			
H8	107	74	VSS	VSS	VSS									
—	108	75	VDD	VDD	VDD									
A9	109	76	PTC4/LLWU_P8	DISABLED		PTC4/LLWU_P8	SPI0_PCS0	UART1_TX	FTM0_CH3		CMP1_OUT		FB_AD11	
D8	110	77	PTC5/LLWU_P9	DISABLED		PTC5/LLWU_P9	SPI0_SCK	LPTMR0_ALT2	XB_IN2		CMP0_OUT	FTM0_CH2	FB_AD10	
C8	111	78	PTC6/LLWU_P10	CMP2_IN4/ CMP0_IN0	CMP2_IN4/ CMP0_IN0	PTC6/LLWU_P10	SPI0_SOUT	PDB0_EXTRG	XB_IN3	UART0_RX	XB_OUT6	I2C0_SCL	FB_AD9	
B8	112	79	PTC7	CMP3_IN4/ CMP0_IN1	CMP3_IN4/ CMP0_IN1	PTC7	SPI0_SIN		XB_IN4	UART0_TX	XB_OUT7	I2C0_SDA	FB_AD8	
A8	113	80	PTC8	HSADC1B_CH11/ CMP0_IN2	HSADC1B_CH11/ CMP0_IN2	PTC8		FTM3_CH4	FLEXPWM1_A2				FB_AD7	



## Pinouts and Packaging

144 MAP BGA	144 LQFP	100 LQFP	Pin Name	Default	ALT0	ALT1	ALT2	ALT3	ALT4	ALT5	ALT6	ALT7	ALT8	ALT9
D7	114	81	PTC9	HSADC1B_CH12/ CMP0_IN3	HSADC1B_CH12/ CMP0_IN3	PTC9		FTM3_CH5	FLEXPWM1_B2				FB_AD6	
C7	115	82	PTC10	HSADC1B_CH13	HSADC1B_CH13	PTC10	I2C1_SCL	FTM3_CH6	FLEXPWM1_A3				FB_AD5	
B7	116	83	PTC11/ LLWU_P11	HSADC1B_CH14	HSADC1B_CH14	PTC11/ LLWU_P11	I2C1_SDA	FTM3_CH7	FLEXPWM1_B3				FB_RW_b	
A7	117	84	PTC12	DISABLED		PTC12	CAN2_TX		FTM_CLKIN0	FLEXPWM1_A1	FTM3_FLT0	SPI2_PCS1	FB_AD27	UART4_RTS_b
D6	118	85	PTC13	DISABLED		PTC13	CAN2_RX		FTM_CLKIN1	FLEXPWM1_B1			FB_AD26	UART4_CTS_b
C6	119	86	PTC14	DISABLED		PTC14	I2C1_SCL	I2C0_SCL		FLEXPWM1_A0			FB_AD25	UART4_RX
B6	120	87	PTC15	DISABLED		PTC15	I2C1_SDA	I2C0_SDA		FLEXPWM1_B0			FB_AD24	UART4_TX
—	121	88	VSS	VSS	VSS									
—	122	89	VDD	VDD	VDD									
A6	123	90	PTC16	DISABLED		PTC16	CAN1_RX	UART3_RX	ENET0_1588_TMR0	FLEXPWM1_A2			FB_CS5_b/ FB_TSIZ1/ FB_BE23_16_b	
D5	124	91	PTC17	DISABLED		PTC17	CAN1_TX	UART3_TX	ENET0_1588_TMR1	FLEXPWM1_B2			FB_CS4_b/ FB_TSIZ0/ FB_BE31_24_b	
C5	125	92	PTC18	DISABLED		PTC18		UART3_RTS_b	ENET0_1588_TMR2	FLEXPWM1_A3			FB_TBST_b/ FB_CS2_b/ FB_BE15_8_b	
B5	126	—	PTC19	DISABLED		PTC19		UART3_CTS_b	ENET0_1588_TMR3	FLEXPWM1_B3			FB_CS3_b/ FB_BE7_0_b	FB_TA_b
A5	127	93	PTD0/ LLWU_P12	DISABLED		PTD0/ LLWU_P12	SPI0_PCS0	UART2_RTS_b	FTM3_CH0	FTM0_CH0	FLEXPWM0_A0		FB_ALE/ FB_CS1_b/ FB_TS_b	FLEXPWM1_A0
D4	128	94	PTD1	HSADC1A_CH11	HSADC1A_CH11	PTD1	SPI0_SCK	UART2_CTS_b	FTM3_CH1	FTM0_CH1	FLEXPWM0_B0		FB_CS0_b	FLEXPWM1_B0
C4	129	95	PTD2/ LLWU_P13	DISABLED		PTD2/ LLWU_P13	SPI0_SOUT	UART2_RX	FTM3_CH2	FTM0_CH2	FLEXPWM0_A1	I2C0_SCL	FB_AD4	FLEXPWM1_A1

144 MAP BGA	144 LQFP	100 LQFP	Pin Name	Default	ALT0	ALT1	ALT2	ALT3	ALT4	ALT5	ALT6	ALT7	ALT8	ALT9
B4	130	96	PTD3	DISABLED		PTD3	SPI0_SIN	UART2_TX	FTM3_CH3	FTM0_CH3	FLEXPWM_0_B1	I2C0_SDA	FB_AD3	FLEXPWM_1_B1
A4	131	97	PTD4/ LLWU_ P14	DISABLED		PTD4/ LLWU_ P14	SPI0_PCS1	UART0_RTS_b	FTM0_CH4	FLEXPWM_0_A2	EWM_IN	SPI1_PCS0	FB_AD2	
A3	132	98	PTD5	HSADC1A_CH8	HSADC1A_CH8	PTD5	SPI0_PCS2	UART0_CTS_b/ UART0_COL_b	FTM0_CH5	FLEXPWM_0_B2	EWM_OUT_b	SPI1_SCK	FB_AD1	
A2	133	99	PTD6/ LLWU_ P15	HSADC1A_CH9	HSADC1A_CH9	PTD6/ LLWU_ P15	SPI0_PCS3	UART0_RX	FTM0_CH6	FTM1_CH0	FTM0_FLT0	SPI1_SOUT	FB_AD0	
M10	134	—	VSS	VSS	VSS									
F8	135	—	VDD	VDD	VDD									
A1	136	100	PTD7	DISABLED		PTD7		UART0_TX	FTM0_CH7	FTM1_CH1	FTM0_FLT1	SPI1_SIN		
C9	137	—	PTD8/ LLWU_ P24	DISABLED		PTD8/ LLWU_ P24	I2C1_SCL	UART5_RX			FLEXPWM_0_A3		FB_A16	
B9	138	—	PTD9	DISABLED		PTD9	I2C1_SDA	UART5_TX			FLEXPWM_0_B3		FB_A17	
B3	139	—	PTD10	DISABLED		PTD10		UART5_RTS_b			FLEXPWM_0_A2		FB_A18	
B2	140	—	PTD11/ LLWU_ P25	DISABLED		PTD11/ LLWU_ P25	SPI2_PCS0	UART5_CTS_b			FLEXPWM_0_B2		FB_A19	
B1	141	—	PTD12	DISABLED		PTD12	SPI2_SCK	FTM3_FLT0	XB_IN5	XB_OUT5	FLEXPWM_0_A1		FB_A20	
C3	142	—	PTD13	DISABLED		PTD13	SPI2_SOUT		XB_IN7	XB_OUT7	FLEXPWM_0_B1		FB_A21	
C2	143	—	PTD14	DISABLED		PTD14	SPI2_SIN		XB_IN11	XB_OUT11	FLEXPWM_0_A0		FB_A22	
C1	144	—	PTD15	DISABLED		PTD15	SPI2_PCS1				FLEXPWM_0_B0		FB_A23	

## 5.2 KV5x Pinouts

The below figure shows the pinout diagram for the devices supported by this document. Many signals may be multiplexed onto a single pin. To determine what signals can be used on which pin, see the previous section.

## Pinouts and Packaging

	1	2	3	4	5	6	7	8	9	10	11	12	
A	PTD7	PTD6/ LLWU_P15	PTD5	PTD4/ LLWU_P14	PTD0/ LLWU_P12	PTC16	PTC12	PTC8	PTC4/ LLWU_P8		PTC3/ LLWU_P7	PTC2	A
B	PTD12	PTD11/ LLWU_P25	PTD10	PTD3	PTC19	PTC15	PTC11/ LLWU_P11	PTC7	PTD9		PTC1/ LLWU_P6	PTC0	B
C	PTD15	PTD14	PTD13	PTD2/ LLWU_P13	PTC18	PTC14	PTC10	PTC6/ LLWU_P10	PTD8/ LLWU_P24		PTB23	PTB22	C
D	PTE2/ LLWU_P1	PTE1/ LLWU_P0	PTE0	PTD1	PTC17	PTC13	PTC9	PTC5/ LLWU_P9	PTB21	PTB20	PTB19	PTB18	D
E	PTE6/ LLWU_P16	PTE5	PTE4/ LLWU_P2	PTE3	VDD	VDD	VDD	VDD	PTB17	PTB16	PTB11	PTB10	E
F	PTE10/ LLWU_P18	PTE9/ LLWU_P17	PTE8	PTE7	VDD	VSS	VSS	VDD	PTB9	PTB8	PTB7	PTB6	F
G	PTE18/ LLWU_P20	PTE19	PTE12	PTE11	VREFH	VREFL	VSS	VSS	PTB5	PTB4	PTB3	PTB2	G
H	PTE16	PTE17/ LLWU_P19	VSS	PTE28	VDDA	VSSA	VSS	VSS	PTB1	PTB0/ LLWU_P5	PTA29	PTA28	H
J	HSADC0A_ CH6	HSADC0A_ CH7/ ADC0_SE4b	ADC0_SE8/ ADC0_DM0/ CMP1_IN2	PTE27	PTA0	PTA1	PTA6	PTA7	PTA13/ LLWU_P4	PTA27	PTA26	PTA25	J
K	PTE20	PTE21	ADC0_SE0/ ADC0_DP0/ CMP2_IN5	PTE26	PTE25/ LLWU_P21	PTA2	PTA3	PTA8	PTA12	PTA16	PTA17	PTA24	K
L	HSADC0A_ CH2/ HSADC1A_ CH2	HSADC0A_ CH3/ HSADC1A_ CH3	PTE30	HSADC0A_ CH12/ CMP0_IN4/ CMP2_IN3	PTE13	VDD	PTA4/ LLWU_P3	PTA9	PTA11/ LLWU_P23	PTA14	PTA15	RESET_b	L
M	HSADC0A_ CH10/ HSADC1B_ CH2	HSADC0A_ CH11/ HSADC1B_ CH3	PTE29	PTE24		PTE23	PTE22	PTA5	PTA10/ LLWU_P22	VSS	PTA19	PTA18	M
	1	2	3	4	5	6	7	8	9	10	11	12	

**Figure 26. 144 MAPBGA Pinout Diagram**

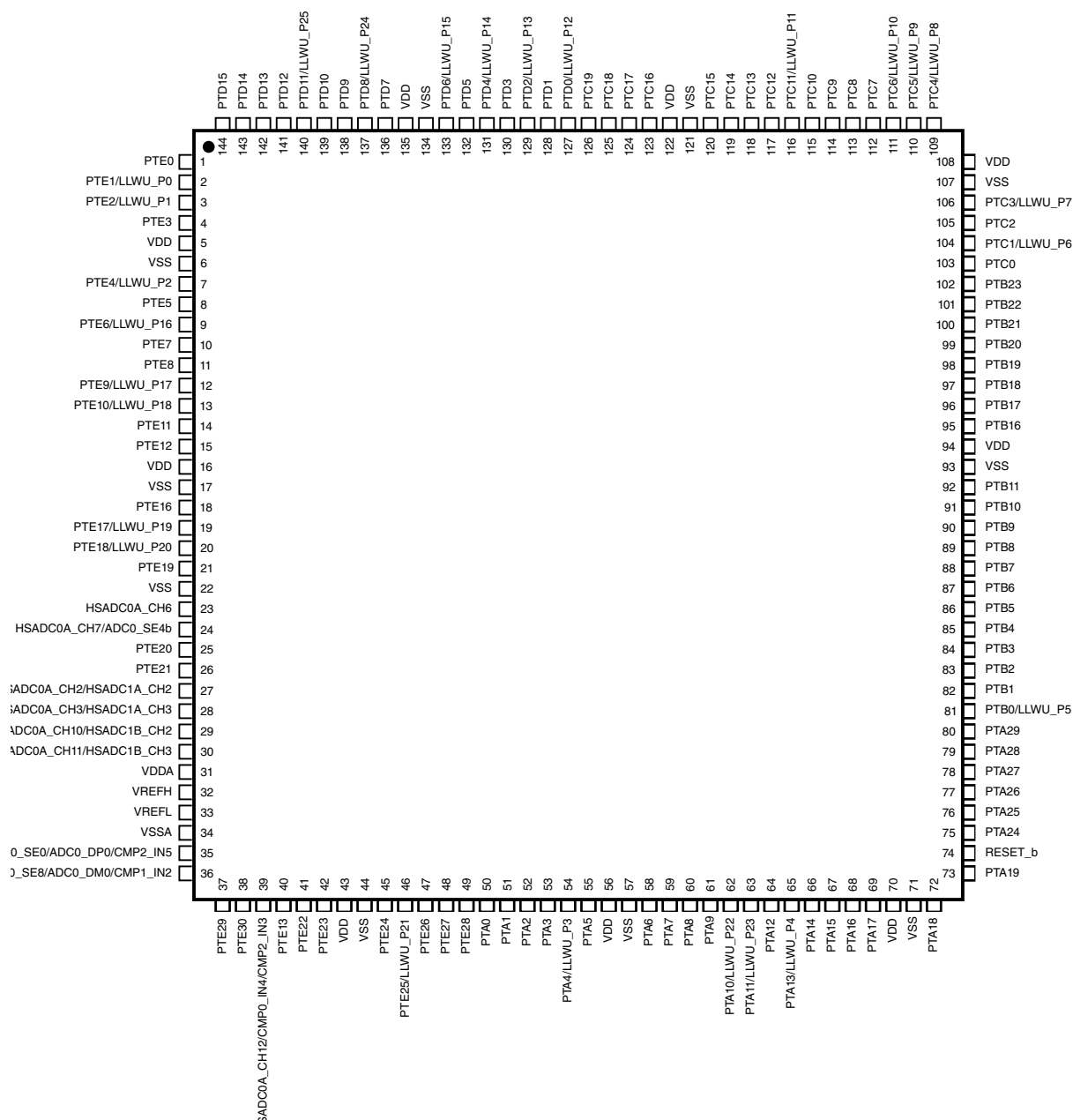

Figure 27. 144 LQFP Pinout Diagram

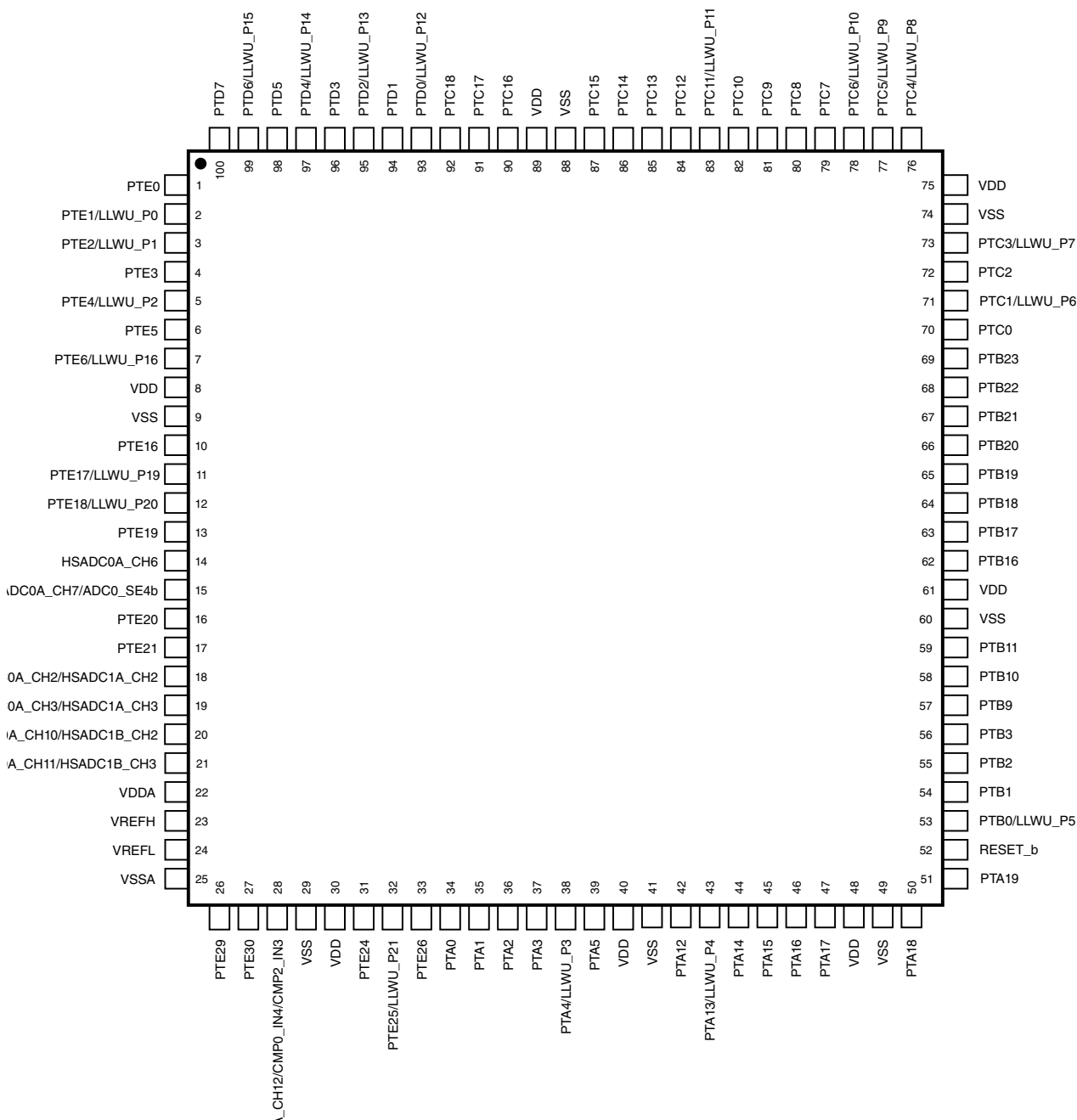

Figure 28. 100 LQFP Pinout Diagram

## 6 Ordering parts

## 6.1 Determining valid orderable parts

Valid orderable part numbers are provided on the web. To determine the orderable part numbers for this device, go to [www.freescale.com](http://www.freescale.com) and perform a part number search for the MKV5x device numbers.

## 7 Part identification

### 7.1 Description

Part numbers for the chip have fields that identify the specific part. You can use the values of these fields to determine the specific part you have received.

### 7.2 Format

Part numbers for this device have the following format:

Q KV## A FFF T PP CC N

### 7.3 Fields

This table lists the possible values for each field in the part number (not all combinations are valid):

Field	Description	Values
Q	Qualification status	<ul style="list-style-type: none"> <li>M = Fully qualified, general market flow</li> <li>P = Prequalification</li> </ul>
KV##	Kinetis family	<ul style="list-style-type: none"> <li>KV58</li> <li>KV56</li> </ul>
A	Key attribute	<ul style="list-style-type: none"> <li>F = Cortex-M7</li> </ul>
FFF	Program flash memory size	<ul style="list-style-type: none"> <li>1M0 = 1 MB</li> <li>512 = 512 KB</li> </ul>
T	Temperature range (°C)	<ul style="list-style-type: none"> <li>V = -40 to 105</li> </ul>
PP	Package identifier	<ul style="list-style-type: none"> <li>LQ = 144 LQFP (20 mm x 20 mm)</li> <li>LL = 100 LQFP (14 mm x 14 mm)</li> <li>MD = 144 MAPBGA (13 mm x 13 mm)</li> </ul>
CC	Maximum CPU frequency (MHz)	<ul style="list-style-type: none"> <li>22 = 220 MHz</li> </ul>
N	Packaging type	<ul style="list-style-type: none"> <li>R = Tape and reel</li> <li>(Blank) = Trays</li> </ul>

## 7.4 Example

This is an example part number:

MKV58F1M0VLQ22

MKV56F512VLL22

## 8 Terminology and guidelines

### 8.1 Definition: Operating requirement

An *operating requirement* is a specified value or range of values for a technical characteristic that you must guarantee during operation to avoid incorrect operation and possibly decreasing the useful life of the chip.

#### 8.1.1 Example

This is an example of an operating requirement:

Symbol	Description	Min.	Max.	Unit
V <sub>DD</sub>	1.0 V core supply voltage	0.9	1.1	V

### 8.2 Definition: Operating behavior

Unless otherwise specified, an *operating behavior* is a specified value or range of values for a technical characteristic that are guaranteed during operation if you meet the operating requirements and any other specified conditions.

#### 8.2.1 Example

This is an example of an operating behavior:



Symbol	Description	Min.	Max.	Unit
$I_{WP}$	Digital I/O weak pullup/pulldown current	10	130	$\mu A$

### 8.3 Definition: Attribute

An *attribute* is a specified value or range of values for a technical characteristic that are guaranteed, regardless of whether you meet the operating requirements.

#### 8.3.1 Example

This is an example of an attribute:

Symbol	Description	Min.	Max.	Unit
CIN_D	Input capacitance: digital pins	—	7	pF

### 8.4 Definition: Rating

A *rating* is a minimum or maximum value of a technical characteristic that, if exceeded, may cause permanent chip failure:

- *Operating ratings* apply during operation of the chip.
- *Handling ratings* apply when the chip is not powered.

#### 8.4.1 Example

This is an example of an operating rating:

Symbol	Description	Min.	Max.	Unit
$V_{DD}$	1.0 V core supply voltage	-0.3	1.2	V

## 8.5 Result of exceeding a rating



## 8.6 Relationship between ratings and operating requirements

<i>Operating rating (min.)</i>	<i>Operating requirement (min.)</i>	<i>Operating requirement (max.)</i>	<i>Operating rating (max.)</i>	
<p>Fatal range</p> <p>Expected permanent failure</p>	<p>Degraded operating range</p> <ul style="list-style-type: none"> <li>- No permanent failure</li> <li>- Possible decreased life</li> <li>- Possible incorrect operation</li> </ul>	<p>Normal operating range</p> <ul style="list-style-type: none"> <li>- No permanent failure</li> <li>- Correct operation</li> </ul>	<p>Degraded operating range</p> <ul style="list-style-type: none"> <li>- No permanent failure</li> <li>- Possible decreased life</li> <li>- Possible incorrect operation</li> </ul>	<p>Fatal range</p> <p>Expected permanent failure</p>
-∞	Operating (power on)			∞

<i>Handling rating (min.)</i>	<i>Handling rating (max.)</i>		
<p>Fatal range</p> <p>Expected permanent failure</p>	<p>Handling range</p> <p>No permanent failure</p>	<p>Fatal range</p> <p>Expected permanent failure</p>	
-∞	Handling (power off)		∞

## 8.7 Guidelines for ratings and operating requirements

Follow these guidelines for ratings and operating requirements:

- Never exceed any of the chip’s ratings.
- During normal operation, don’t exceed any of the chip’s operating requirements.
- If you must exceed an operating requirement at times other than during normal operation (for example, during power sequencing), limit the duration as much as possible.

## 8.8 Definition: Typical value

A *typical value* is a specified value for a technical characteristic that:

- Lies within the range of values specified by the operating behavior
- Given the typical manufacturing process, is representative of that characteristic during operation when you meet the typical-value conditions or other specified conditions

Typical values are provided as design guidelines and are neither tested nor guaranteed.

### 8.8.1 Example 1

This is an example of an operating behavior that includes a typical value:

Symbol	Description	Min.	Typ.	Max.	Unit
$I_{WP}$	Digital I/O weak pullup/pulldown current	10	70	130	$\mu A$

### 8.8.2 Example 2

This is an example of a chart that shows typical values for various voltage and temperature conditions:

## Revision History

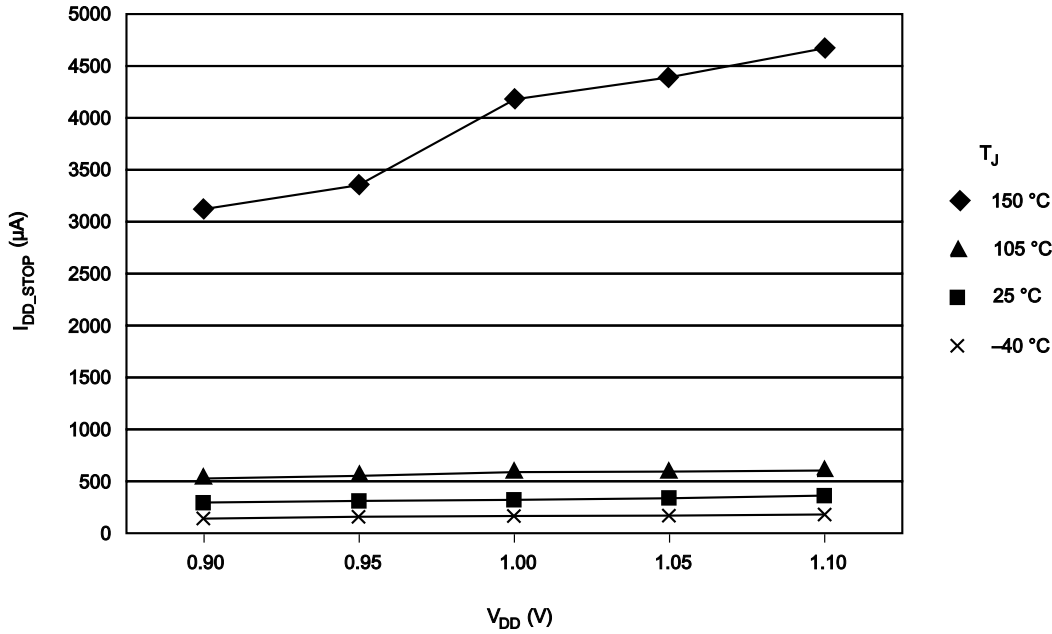

## 8.9 Typical Value Conditions

Typical values assume you meet the following conditions (or other conditions as specified):

Symbol	Description	Value	Unit
T <sub>A</sub>	Ambient temperature	25	°C
V <sub>DD</sub>	3.3 V supply voltage	3.3	V

## 9 Revision History

The following table provides a revision history for this document.

**Table 38. Revision History**

Rev. No.	Date	Substantial Changes
0	02/2015	Initial release
1	06/2015	<ul style="list-style-type: none"> <li>Updated the features list to include FlexBus, TRNG, MMCAU, Advanced WatchDog Timer and JTAG modules</li> <li>Updated the ordering information table to highlight differences in the parts in terms of flash, SRAM, modules or instances.</li> </ul>

*Table continues on the next page...*

**Table 38. Revision History (continued)**

Rev. No.	Date	Substantial Changes
		<ul style="list-style-type: none"> <li>• Added KV5x block diagram</li> <li>• Editorial changes in the table "Recommended Operating Conditions."</li> <li>• Removed the Typical values column from the table "Recommended Operating Conditions."</li> <li>• Removed the following parameters from the table "Recommended Operating Conditions."               <ul style="list-style-type: none"> <li>• Output Source Current High (<math>I_{OH}</math>)</li> <li>• Output Source Current Low (<math>I_{OL}</math>)</li> <li>• Oscillator Input Voltage High (<math>V_{IHOSC}</math>)</li> <li>• Oscillator Input Voltage Low (<math>V_{ILOSC}</math>)</li> <li>• DAC Output Current Drive Strength (<math>C_{out}</math>)</li> </ul> </li> <li>• Added HVD characteristics to the table "LVD, and POR operating requirements" and changed the title to HVD, LVD, and POR operating requirements."</li> <li>• Added the following parameters to the table "Voltage and current operating behaviors"               <ul style="list-style-type: none"> <li>• Output high current total for all ports (<math>I_{OHT}</math>)</li> <li>• Output low current total for all ports (<math>I_{OHL}</math>)</li> <li>• Internal pull-down resistance (<math>R_{PD}</math>)</li> </ul> </li> <li>• Removed the footnote "PTC6 and PTC7 are true open drain so have no high drive output transistor so there is no VOH spec for them. These pins must be terminated with a pull-up resistor to VDD" from the table "Voltage and current operating behaviors"</li> <li>• Added a note above the table "Low power mode peripheral adders — typical value" suggesting that the values are preliminary data.</li> <li>• Updated the notes in the table "Power consumption operating behaviors" for run mode currents with all peripherals disabled.</li> <li>• Updated the table "EMC radiated emissions operating behaviors" by splitting description column into Conditions and Clocks columns.</li> <li>• Changed Typ. values to TBDs in the table "EMC radiated emissions operating behaviors."</li> <li>• Updated the table "Typical device clock specifications"</li> <li>• Added a footnote to the ambient temperature entry in the table "Thermal operating requirements"</li> <li>• Updated the table "Thermal attributes"</li> <li>• Changed ADC to HSADC in the title of the section "12-bit SAR High Speed Analog-to-Digital Converter (ADC) parameters"</li> <li>• Changed minimum operating voltage value from 2.7 V to 1.71 V in the table "MII signal switching specifications" and RMI signal switching specifications."</li> </ul>
2	10/2015	<ul style="list-style-type: none"> <li>• Updated the part numbers in the table Orderable part numbers summary and the front page</li> <li>• In the features list:               <ul style="list-style-type: none"> <li>• Updated the instances of UART and SPI modules</li> <li>• Added Ether module to the list of communication interfaces</li> <li>• Remove Micro Trace Buffer from the list of System peripherals</li> <li>• In table <a href="#">Operating Requirements</a>, removed rows for <math>N_F</math>, <math>T_R</math>, and <math>t_{FLRET}</math></li> </ul> </li> <li>• In table <a href="#">PORT Voltage and current operating behaviors</a>, added <math>I_{CIO}</math>, <math>I_{Ccont}</math>, and <math>V_{ODPU}</math> rows</li> <li>• Updated table <a href="#">Power mode transition operating behaviors</a></li> <li>• Updated table <a href="#">Power consumption operating behaviors</a></li> <li>• Updated table <a href="#">EMC radiated emissions operating behaviors</a></li> <li>• Updated table <a href="#">General switching specifications</a></li> <li>• In section <a href="#">DSPI switching specifications (limited voltage range)</a> <ul style="list-style-type: none"> <li>• Removed the notes</li> <li>• Removed table "Master mode DSPI timing for fast pads (limited voltage range)"</li> </ul> </li> </ul>

**Table 38. Revision History**

Rev. No.	Date	Substantial Changes
		<ul style="list-style-type: none"> <li>• Removed the table "Master mode DSPI timing for open drain pads (limited voltage range)"</li> <li>• Removed the table "Slave mode DSPI timing for fast pads (limited voltage range)"</li> <li>• Removed the table "Slave mode DSPI timing for open drain pads (limited voltage range)"</li> <li>• Removed the table "Master mode DSPI timing fast pads (full voltage range)"</li> <li>• Removed the table "Master mode DSPI timing open drain pads (full voltage range)"</li> <li>• Removed the table "Slave mode DSPI timing for fast pads (full voltage range)"</li> <li>• Removed the table "Slave mode DSPI timing for open drain pads (full voltage range)"</li> <li>• Updated the pinouts</li> <li>• Updated table <a href="#">Device clock specifications</a></li> </ul>

**How to Reach Us:**

**Home Page:**

[freescale.com](http://freescale.com)

**Web Support:**

[freescale.com/support](http://freescale.com/support)

Information in this document is provided solely to enable system and software implementers to use Freescale products. There are no express or implied copyright licenses granted hereunder to design or fabricate any integrated circuits based on the information in this document. Freescale reserves the right to make changes without further notice to any products herein.

Freescale makes no warranty, representation, or guarantee regarding the suitability of its products for any particular purpose, nor does Freescale assume any liability arising out of the application or use of any product or circuit, and specifically disclaims any and all liability, including without limitation consequential or incidental damages. "Typical" parameters that may be provided in Freescale data sheets and/or specifications can and do vary in different applications, and actual performance may vary over time. All operating parameters, including "typicals," must be validated for each customer application by customer's technical experts. Freescale does not convey any license under its patent rights nor the rights of others. Freescale sells products pursuant to standard terms and conditions of sale, which can be found at the following address: [freescale.com/SalesTermsandConditions](http://freescale.com/SalesTermsandConditions).

Freescale, the Freescale logo, and Kinetis are trademarks of Freescale Semiconductor, Inc., Reg. U.S. Pat. & Tm. Off. All other product or service names are the property of their respective owners. ARM, the ARM Powered logo, and Cortex are registered trademarks of ARM Limited. All rights reserved.

©2015 Freescale Semiconductor, Inc.