

Surface Mount Transient Voltage Suppressor

Uni-directional

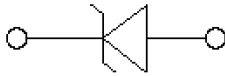

Bi-directional



Features

- For surface mounted applications
- Low-profile package
- Ideal for automated placement
- Available in Unidirectional and Bidirectional
- 200 W peak pulse power capability with a 10/1000 μ s waveform
- Low incremental surge resistance, excellent clamping capability
- Very fast response time
- High temperature soldering guaranteed: 260 °C/10 s at terminals
- Meets MSL level 1
- Component in accordance to RoHS

Typical Applications

Use in sensitive electronics protection against voltage transients induced by inductive load switching and lighting on ICs, MOSFET, signal lines of sensor units for consumer, computer, industrial, telecommunication.

Mechanical Date

- **Package:** SOD-123FL
Molding compound meets UL 94 V-0 flammability rating, RoHS-compliant, halogen-free
- **Terminals:** Tin plated leads, solderable per J-STD-002 and JESD22-B102
- **Polarity:** For uni-directional types the band denotes cathode end, no marking on bi-directional types

■Maximum Ratings (Ta=25°C Unless otherwise specified)

| PARAMETER | SYMBOL | UNIT | Conditions | Max |
|---|-----------------------------------|------|------------------------------|------------------|
| Peak power dissipation ⁽¹⁾ (2) (Fig.1) | P _{PPM} | W | with a 10/1000us waveform | 200 |
| Peak pulse current ⁽¹⁾ | I _{PPM} | A | with a 10/1000us waveform | (See Next Table) |
| Power dissipation, on infinite heat sink | P _D | W | TL=75°C | 0.4 |
| Peak forward surge current, 8.3 ms single half sine-wave unidirectional only ⁽³⁾ | I _{FSM} | A | | 20 |
| Operating junction and storage temperature range | T _J , T _{STG} | °C | | -55 to +150 |
| Thermal resistance | R _{θJL} | °C/W | Between junction and lead | 26 |
| | R _{θJA} | | Between junction and Ambient | 300 |
| | R _{θJC} | | Between junction and Curve | 40 |

Notes:

- (1). Non repetitive current pulse, per Fig2 and derated above TA=25°C per Fig3.
- (2). $T_L=30^\circ\text{C}$ unless otherwise noted, $V_F \leq 1.25\text{V}@200\text{mA}$.
- (3). Measured on 8.3 ms single half sine-wave or equivalent square wave, duty cycle = 4 pulses per minute maximum

■ Ordering Information (Example)

| PREFERED P/N | PACKING CODE | UNIT WEIGHT(g) | MINIMUM PACKAGE(pcs) | INNER BOX QUANTITY(pcs) | OUTER CARTON QUANTITY(pcs) | DELIVERY MODE |
|--------------|--------------|----------------|----------------------|-------------------------|----------------------------|---------------|
| SMF SERIES | F1 | 0.0167 | 3000 | 30000 | 120000 | 7" reel |
| SMF SERIES | F2 | 0.0167 | 10000 | 20000 | 160000 | 13" reel |

■ Electrical Characteristics (TA=25°C unless otherwise noted)

| Part Number | | Marking | | Breakdown Voltage $V_{BR}@I_T$ | | | Maximum Reverse Leakage $I_R^{(3)}@V_{RWM}$ (μA) | Working Peak Reverse Voltage V_{RWM} (V) | Maximum Reverse Surge Current $I_{PP}^{(2)}$ (A) | Maximum Clamping Voltage $V_C@I_{FP}$ (V) |
|-------------|----------|---------|-------|--------------------------------|---------|------------------|---|--|--|---|
| (Uni) | (Bi) | (Uni) | (Bi) | Min(V) | Max (V) | $I_T^{(1)}$ (mA) | | | | |
| SMF5.0A | SMF5.0CA | 5.0A | 5.0CA | 6.40 | 7.07 | 10 | 400.0 | 5.0 | 21.74 | 9.2 |
| SMF6.0A | SMF6.0CA | 6.0A | 6.0CA | 6.67 | 7.37 | 10 | 400.0 | 6.0 | 19.42 | 10.3 |
| SMF6.5A | SMF6.5CA | 6.5A | 6.5CA | 7.22 | 7.98 | 10 | 250.0 | 6.5 | 17.86 | 11.2 |
| SMF7.0A | SMF7.0CA | 7.0A | 7.0CA | 7.78 | 8.60 | 10 | 100.0 | 7.0 | 16.67 | 12.0 |
| SMF7.5A | SMF7.5CA | 7.5A | 7.5CA | 8.33 | 9.21 | 1 | 50.0 | 7.5 | 15.50 | 12.9 |
| SMF8.0A | SMF8.0CA | 8.0A | 8.0CA | 8.89 | 9.83 | 1 | 25.0 | 8.0 | 14.71 | 13.6 |
| SMF8.5A | SMF8.5CA | 8.5A | 8.5CA | 9.44 | 10.40 | 1 | 10.0 | 8.5 | 13.89 | 14.4 |
| SMF9.0A | SMF9.0CA | 9.0A | 9.0CA | 10.00 | 11.10 | 1 | 5.0 | 9.0 | 12.99 | 15.4 |
| SMF10A | SMF10CA | 10A | 10CA | 11.10 | 12.30 | 1 | 2.5 | 10.0 | 11.76 | 17.0 |
| SMF11A | SMF11CA | 11A | 11CA | 12.20 | 13.50 | 1 | 2.5 | 11.0 | 10.99 | 18.2 |
| SMF12A | SMF12CA | 12A | 12CA | 13.30 | 14.70 | 1 | 2.5 | 12.0 | 10.05 | 19.9 |
| SMF13A | SMF13CA | 13A | 13CA | 14.40 | 15.90 | 1 | 1.0 | 13.0 | 9.30 | 21.5 |
| SMF14A | SMF14CA | 14A | 14CA | 15.60 | 17.20 | 1 | 1.0 | 14.0 | 8.62 | 23.2 |
| SMF15A | SMF15CA | 15A | 15CA | 16.70 | 18.50 | 1 | 1.0 | 15.0 | 8.20 | 24.4 |
| SMF16A | SMF16CA | 16A | 16CA | 17.80 | 19.70 | 1 | 1.0 | 16.0 | 7.69 | 26.0 |
| SMF17A | SMF17CA | 17A | 17CA | 18.90 | 20.90 | 1 | 1.0 | 17.0 | 7.25 | 27.6 |
| SMF18A | SMF18CA | 18A | 18CA | 20.00 | 22.10 | 1 | 1.0 | 18.0 | 6.85 | 29.2 |
| SMF19A | SMF19CA | 19A | 19CA | 21.10 | 23.30 | 1 | 1.0 | 19.0 | 6.54 | 30.6 |
| SMF20A | SMF20CA | 20A | 20CA | 22.20 | 24.50 | 1 | 1.0 | 20.0 | 6.17 | 32.4 |
| SMF22A | SMF22CA | 22A | 22CA | 24.40 | 26.90 | 1 | 1.0 | 22.0 | 5.63 | 35.5 |
| SMF24A | SMF24CA | 24A | 24CA | 26.70 | 29.50 | 1 | 1.0 | 24.0 | 5.14 | 38.9 |
| SMF26A | SMF26CA | 26A | 26CA | 28.90 | 31.90 | 1 | 1.0 | 26.0 | 4.75 | 42.1 |
| SMF28A | SMF28CA | 28A | 28CA | 31.10 | 34.40 | 1 | 1.0 | 28.0 | 4.41 | 45.4 |
| SMF30A | SMF30CA | 30A | 30CA | 33.30 | 36.80 | 1 | 1.0 | 30.0 | 4.13 | 48.4 |
| SMF33A | SMF33CA | 33A | 33CA | 36.70 | 40.60 | 1 | 1.0 | 33.0 | 3.75 | 53.3 |
| SMF36A | SMF36CA | 36A | 36CA | 40.00 | 44.20 | 1 | 1.0 | 36.0 | 3.44 | 58.1 |
| SMF40A | SMF40CA | 40A | 40CA | 44.40 | 49.10 | 1 | 1.0 | 40.0 | 3.10 | 64.5 |
| SMF43A | SMF43CA | 43A | 43CA | 47.80 | 52.80 | 1 | 1.0 | 43.0 | 2.88 | 69.4 |
| SMF45A | SMF45CA | 45A | 45CA | 50.00 | 55.30 | 1 | 1.0 | 45.0 | 2.75 | 72.7 |
| SMF48A | SMF48CA | 48A | 48CA | 53.30 | 58.90 | 1 | 1.0 | 48.0 | 2.58 | 77.4 |
| SMF51A | SMF51CA | 51A | 51CA | 56.70 | 62.70 | 1 | 1.0 | 51.0 | 2.43 | 82.4 |
| SMF54A | SMF54CA | 54A | 54CA | 60.00 | 66.30 | 1 | 1.0 | 54.0 | 2.30 | 87.1 |
| SMF58A | SMF58CA | 58A | 58CA | 64.40 | 71.20 | 1 | 1.0 | 58.0 | 2.14 | 93.6 |

| Part Number | | Marking | | Breakdown Voltage $V_{BR}@I_T$ | | | Maximum Reverse Leakage $I_R^{(3)}$ @ V_{RWM} (μA) | Working Peak Reverse Voltage V_{RWM} (V) | Maximum Reverse Surge Current $I_{PP}^{(2)}$ (A) | Maximum Clamping Voltage $V_C @ I_{PP}$ (V) |
|-------------|----------|---------|-------|--------------------------------|---------|------------------|---|--|--|---|
| (Uni) | (Bi) | (Uni) | (Bi) | Min(V) | Max (V) | $I_T^{(1)}$ (mA) | | | | |
| SMF60A | SMF60CA | 60A | 60CA | 66.70 | 73.70 | 1 | 1.0 | 60.0 | 2.07 | 96.8 |
| SMF64A | SMF64CA | 64A | 64CA | 71.10 | 78.60 | 1 | 1.0 | 64.0 | 1.94 | 103.0 |
| SMF70A | SMF70CA | 70A | 70CA | 77.80 | 86.00 | 1 | 1.0 | 70.0 | 1.77 | 113.0 |
| SMF75A | SMF75CA | 75A | 75CA | 83.30 | 92.10 | 1 | 1.0 | 75.0 | 1.65 | 121.0 |
| SMF78A | SMF78CA | 78A | 78CA | 86.70 | 95.80 | 1 | 1.0 | 78.0 | 1.59 | 126.0 |
| SMF80A | SMF80CA | 80A | 80CA | 88.80 | 97.60 | 1 | 1.0 | 80.0 | 1.55 | 129.0 |
| SMF85A | SMF85CA | 85A | 85CA | 94.40 | 104.00 | 1 | 1.0 | 85.0 | 1.46 | 137.0 |
| SMF90A | SMF90CA | 90A | 90CA | 100.00 | 111.00 | 1 | 1.0 | 90.0 | 1.37 | 146.0 |
| SMF100A | SMF100CA | 100A | 100CA | 111.00 | 123.00 | 1 | 1.0 | 100.0 | 1.23 | 162.0 |
| SMF110A | SMF110CA | 110A | 110CA | 122.00 | 135.00 | 1 | 1.0 | 110.0 | 1.13 | 177.0 |
| SMF120A | SMF120CA | 120A | 120CA | 133.00 | 147.00 | 1 | 1.0 | 120.0 | 1.04 | 193.0 |
| SMF130A | SMF130CA | 130A | 130CA | 144.00 | 159.00 | 1 | 1.0 | 130.0 | 0.96 | 209.0 |
| SMF140A | SMF140CA | 140A | 140CA | 155.00 | 171.00 | 1 | 1.0 | 140.0 | 0.89 | 224.0 |
| SMF150A | SMF150CA | 150A | 150CA | 167.00 | 185.00 | 1 | 1.0 | 150.0 | 0.82 | 243.0 |
| SMF160A | SMF160CA | 160A | 160CA | 178.00 | 197.00 | 1 | 1.0 | 160.0 | 0.77 | 259.0 |
| SMF170A | SMF170CA | 170A | 170CA | 189.00 | 209.00 | 1 | 1.0 | 170.0 | 0.73 | 275.0 |
| SMF180A | SMF180CA | 180A | 180CA | 200.00 | 220.00 | 1 | 1.0 | 180.0 | 0.68 | 292.0 |
| SMF190A | SMF190CA | 190A | 190CA | 211.00 | 232.00 | 1 | 1.0 | 190.0 | 0.65 | 308.0 |
| SMF200A | SMF200CA | 200A | 200CA | 224.00 | 247.00 | 1 | 1.0 | 200.0 | 0.62 | 324.0 |
| SMF220A | SMF220CA | 220A | 220CA | 246.00 | 272.00 | 1 | 1.0 | 220.0 | 0.56 | 356.0 |

Notes:

- (1) $t_p \leq 50ms$ Pulse test: $t_p \leq 50ms$.
- (2) Surge current waveform per Fig. 2 and derated per Fig.3.
- (3) For bi-directional types having V_{RWM} of 10 V and less, the I_R limit is doubled.

■ Characteristics(Typical)

FIG1: Peak Pulse Power Rating Curve

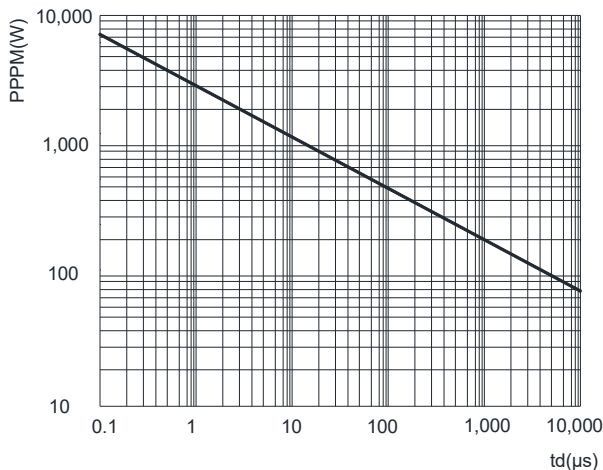
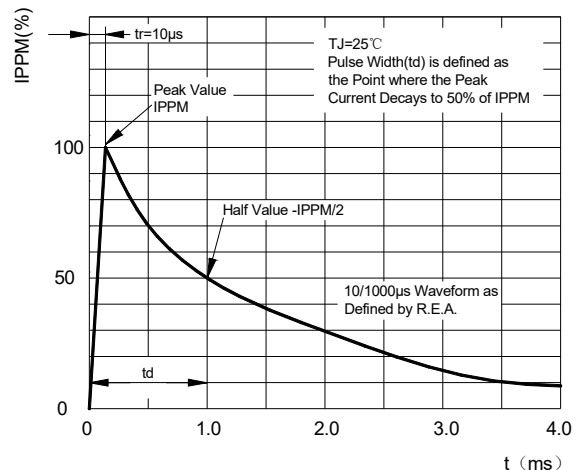
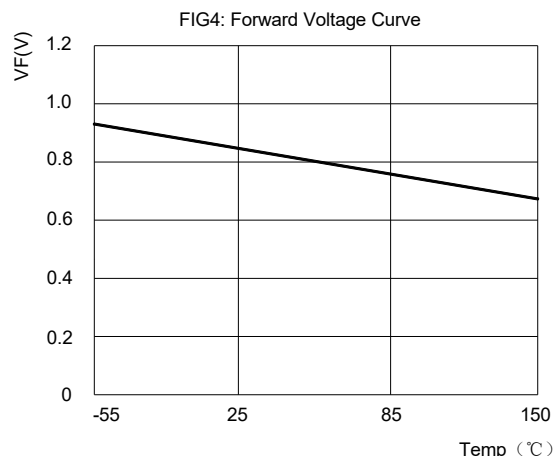
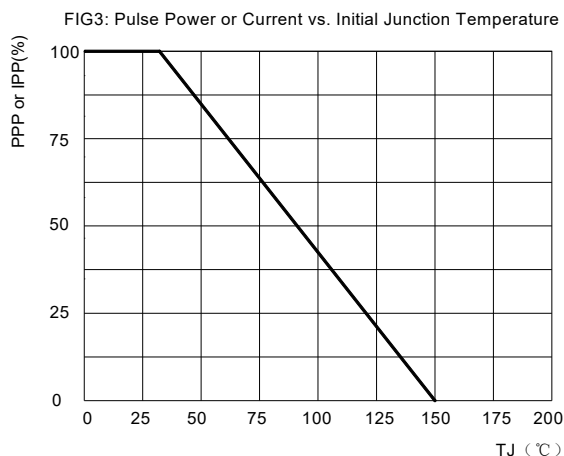

FIG2: Pulse Waveform



■ Characteristics(Typical)



■ Outline Dimensions

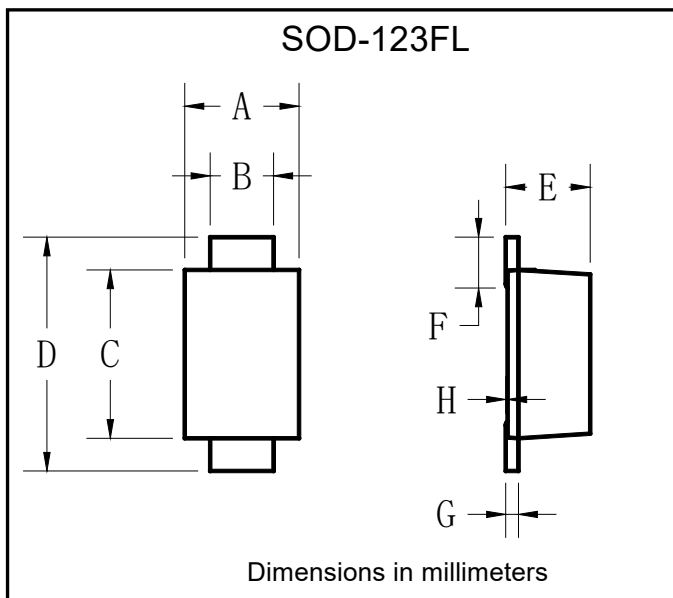

| SOD-123FL | | |
|-----------|------|------|
| Dim | Min | Max |
| A | 1.60 | 1.90 |
| B | 0.90 | 1.10 |
| C | 2.55 | 2.85 |
| D | 3.60 | 3.90 |
| E | 1.00 | 1.20 |
| F | 0.40 | 0.90 |
| G | 0.10 | 0.25 |
| H | 0.02 | 0.05 |

■ Suggested pad layout

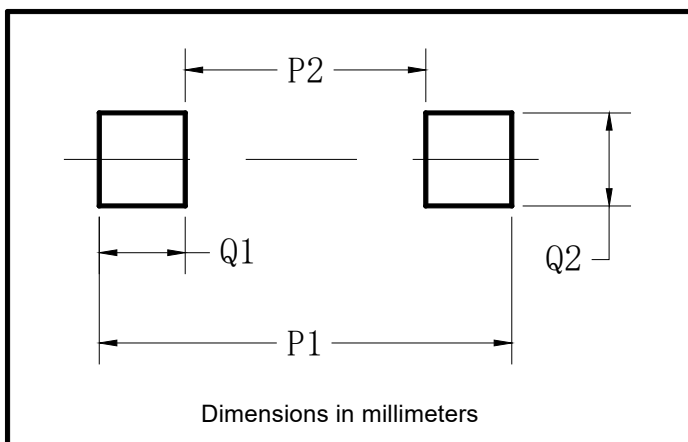

| SOD-123FL | |
|-----------|-------------|
| Dim | Millimeters |
| P1 | 3.90 |
| P2 | 1.90 |
| Q1 | 1.00 |
| Q2 | 1.50 |